

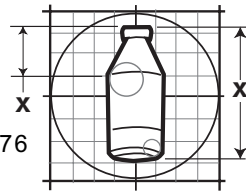

092 Package Vending Specification

426 Industrial Boulevard • Kearneysville WV 25430-2776
 Phone: (304) 728-7056 • Fax: (304) 725-6579



PAGE: 1 of 4
DATE: 2 Mar 06
REVISION: 07

PRODUCT NAME: Nesquik 13.5 oz. MilkShake
BOTTLER / COMPANY: Nestlé USA Inc.
VOLUME: 13.5 oz. / 399 mL
PACKAGE TYPE: Plastic
HEIGHT: 7.24 in. / 183.9 cm
DIAMETER: 2.66 in. / 67.6 cm
WEIGHT: 0.99 lbs. / 0.45 kg
COUNTRY OF ORIGIN: USA

The Nesquik Vend Kits were developed to enhance the vending reliability of the Nesquik bottles. Royal Vendors has found through on-going testing of the Nesquik product that these packages tend to become distorted depending on the length of time the package has been in the column and to some degree on the specific temperature of the package when vended. The setup described in this specification takes all these issues into account to maximize the vending reliability of this package.



APPROVED VENDERS				
VENDER	RETAINERS		72" CAPACITY	
	Front	Rear	Front	Rear
Milk Vender	6	6	26	26

KITS / PARTS: *Milk venders with no kits currently installed:* 332122 Nesquik 13.5 / 14 oz. Front Column Vend Kit (one per front column); 332123 Nesquik 13.5 / 14 oz. Rear Column Vend Kit (one per rear column); 827004 Anti-friction Sheet Silicone. *Milk venders with kits for 16 oz. Nesquik bottle currently installed:* 332124 Nesquik 16 - 13.5 / 14 oz. Conversion Kit (one kit for each column, front or rear).

MILK VENDER INSTALLATION INSTRUCTIONS:

NOTE: For Milk Venders with 16 oz. Nesquik Bottle Kits already installed, skip instruction items 3 and 4.

NOTE: The 16 oz. Nesquik bottle can be vended with the 13.5 oz. Vend Kits installed in the Milk Vender.

1. Remove power from the vender by unplugging the vender's main power cord from the AC voltage source (outlet).
2. Remove all product from the columns to be converted.
3. Remove the rubber strip on the top left-side column wall which is used to secure product retainers.
4. **FRONT COLUMNS:** Remove the product retainers and the plastic baffle from the column. Install a bottle filler as shown in Figure 1. Install the filler plate by placing it all the way against the center divider channel, so that the filler plate's top tab slides into position 9 and the bottom tab slides securely into the square hole in the baffle nearest the divider. (See Figure 4.) Install an anti-friction sheet so that the top of the sheet is at the laser line on the filler plate, with the bottom portion of the sheet on the baffle. Apply a thin coat of silicone to the anti-friction sheet after it is installed. Attach one of the black extrusions from the kit to the left product retainer. (See Figure 2.)
REAR COLUMNS: Move the back spacer assembly all the way to the rear, and remove the plastic baffle from the column. Install a bottle filler as shown in Figure 1. Install the filler plate by placing the top tab in the position closest to the divider channel. Install an anti-friction sheet so that the top of the sheet is at the laser line on the filler plate, with the bottom portion of the sheet on the baffle. (See Figure 5.) Apply a thin coat of silicone to the anti-friction sheet after it is installed.
5. Install front column retainers in position 6, counting from the front. Install rear column back spacers in position 6, counting from the rear.
6. Attach one divider extrusion to the left side of the center channel. (See Figure 3.)
7. Install one column extrusion on the right-side column wall. (See Figure 6.)
8. Load bottles with caps alternating front to rear. (**Important:** See loading instructions and photos on page 4.)
9. Restore power to the vender by plugging the vender's main power cord into the AC voltage source (outlet).

ANY QUESTIONS??? CONTACT ROYAL VENDORS' CUSTOMER SERVICE DEPARTMENT
CALL TOLL FREE (800) 931-9214



092 Package Vending Specification

426 Industrial Boulevard • Kearneysville WV 25430-2776
 Phone: (304) 728-7056 • Fax: (304) 725-6579

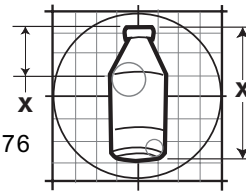

PAGE: 2 of 4
DATE: 2 Mar 06
REVISION: 07

PRODUCT NAME: Nesquik 13.5 oz. MilkShake

Figure 1

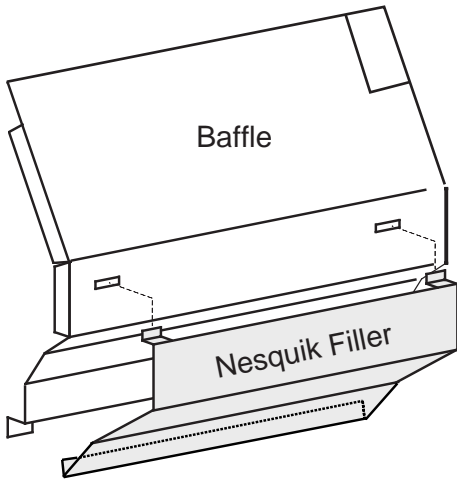

Figure 2

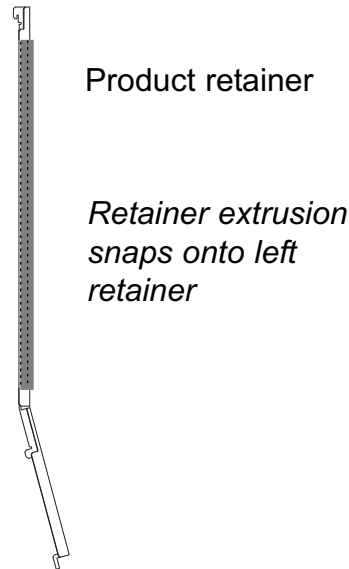

Figure 3

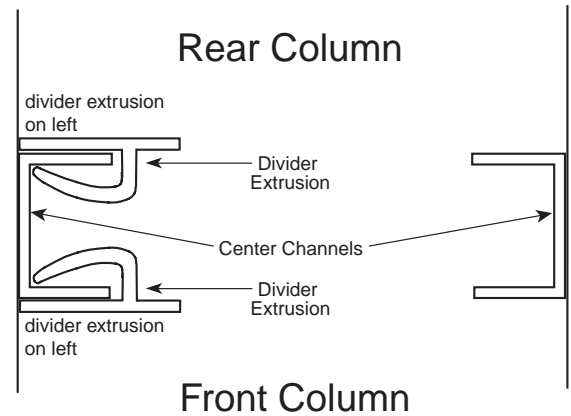
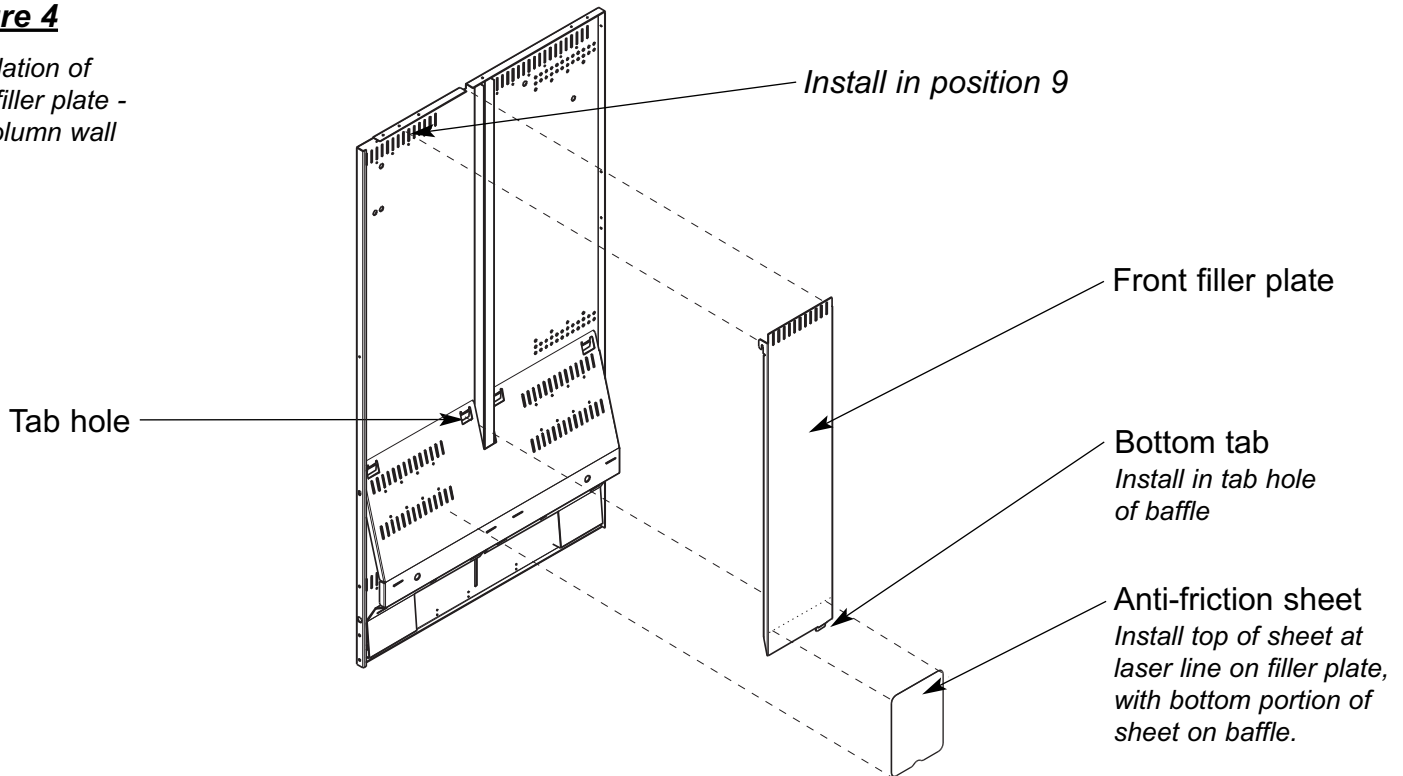

Figure 4

Installation of front filler plate - left column wall



**ANY QUESTIONS??? CONTACT ROYAL VENDORS' CUSTOMER SERVICE DEPARTMENT
 CALL TOLL FREE (800) 931-9214**



092 Package Vending Specification

426 Industrial Boulevard • Kearneysville WV 25430-2776
Phone: (304) 728-7056 • Fax: (304) 725-6579

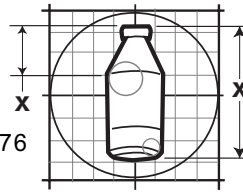

PAGE: 3 of 4

DATE: 2 Mar 06

REVISION: 07

PRODUCT NAME: Nesquik 13.5 oz. MilkShake

Figure 5

Installation of rear filler plate - left column wall

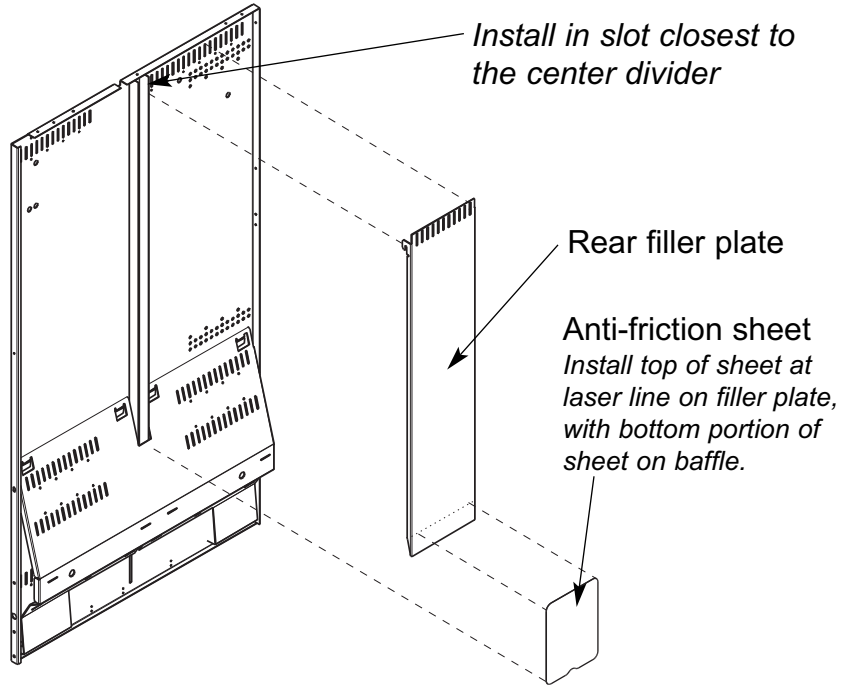
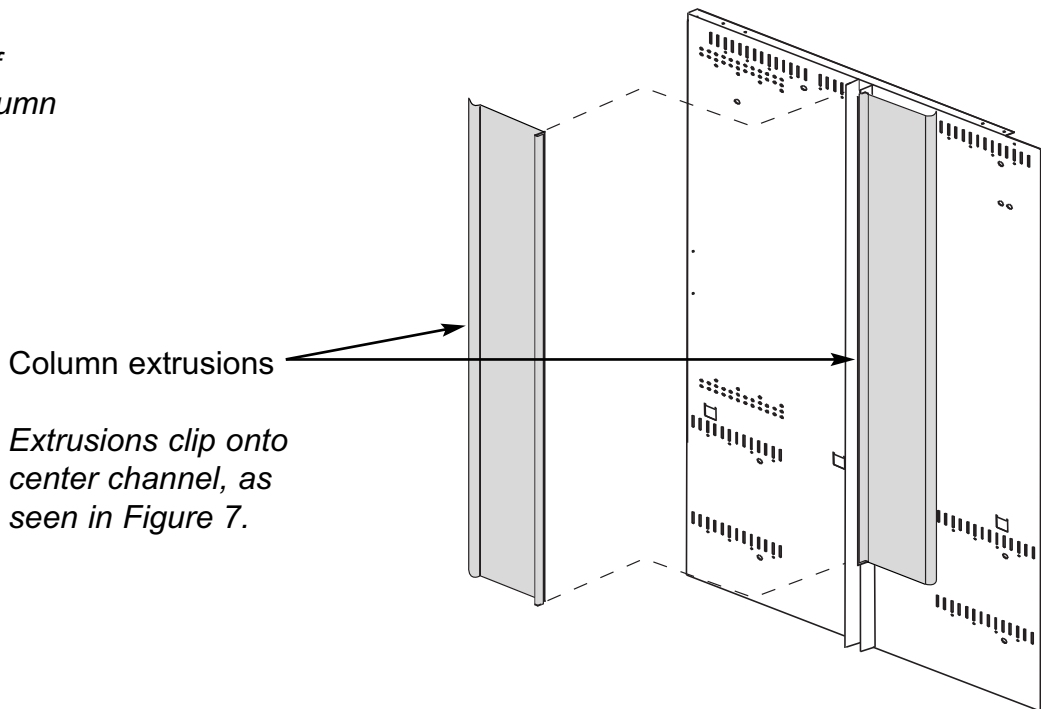

Figure 6

Installation of right-side column extrusions



**ANY QUESTIONS??? CONTACT ROYAL VENDORS' CUSTOMER SERVICE DEPARTMENT
CALL TOLL FREE (800) 931-9214**



092

Package Vending Specification

426 Industrial Boulevard • Kearneysville WV 25430-2776
 Phone: (304) 728-7056 • Fax: (304) 725-6579

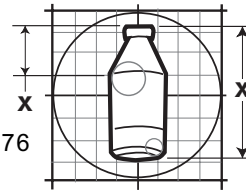

PAGE: 4 of 4
 DATE: 2 Mar 06
 REVISION: 07

PRODUCT NAME: Nesquik 13.5 oz. MilkShake

Figure 7

Top View

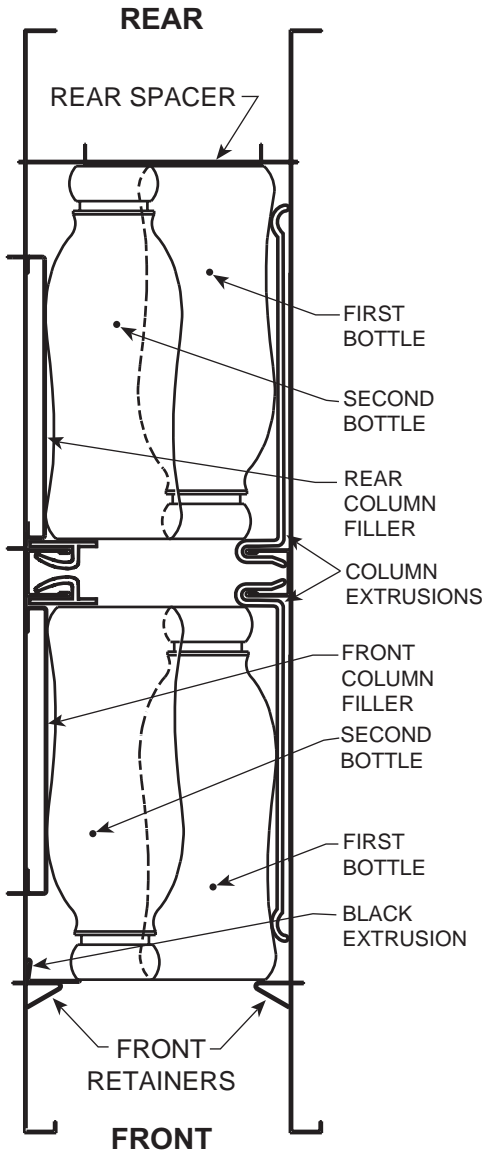

Rear column properly loaded



NOTES:

1. Care should be taken when loading product into the front and rear columns to prevent product migration or other vending errors. Do not exceed recommended loading capacity.
2. **Rear column loading instructions:** On the initial product fill, load the first bottle with the cap to the front on the right side of the column, and reverse the direction of the second bottle loaded so it is loaded on the left side with the cap to the back. Continue alternating bottle directions, such that the caps are always to the front on the right-side packages within the column. Each time the column is filled, the last package should be on the left side with the cap towards the back.
3. **Front column loading instructions:** On the initial product fill, load the first bottle with the cap to the back on the right side of the column, and reverse the direction of the second bottle loaded so it is loaded on the left side with the cap to the front. Continue alternating bottle directions, such that the caps are always to the back on the right-side packages within the column. Each time the column is filled, the last package should be on the left side with the cap towards the front.



Front column properly loaded



**ANY QUESTIONS??? CONTACT ROYAL VENDORS' CUSTOMER SERVICE DEPARTMENT
 CALL TOLL FREE (800) 931-9214**