



SERVICE BULLETIN # 00052

201 INDUSTRIAL BOULEVARD • KEARNEYSVILLE, WV 25430

Phone: (304) 728-7056 • Fax: (304) 725-6579 • Toll Free: (800) 931-9214

PAGE: 1 of 1

DATE: 6-19-02

REVISION: 05

SUBJECT: Filter Assembly Installation

MODELS: Merlin 2000, Merlin III

KIT NUMBER	KIT DESCRIPTION
------------	-----------------

011124	P.O. 1080 and after
--------	---------------------

011123	P.O. 1079 and before
--------	----------------------

BEFORE WORKING ON VENDER: Remove power from vender by unplugging vender's main power cord from the AC voltage power source (wall outlet).



The following areas of this vender contain voltage, which can cause serious injury or even death. The main power cord, supplying 110 VAC to the evaporator, EMI filter, and refrigeration system. The power line from the EMI filter to the ballast and transformer. The ballast can produce upwards of 600 volts. Remove power from vender before working in any of these areas.

Line Filter

Ground Wire Assembly - Filter

Connect to Main Wiring Harness

.250 Housing (4) Req'd

Connect to Door Harness

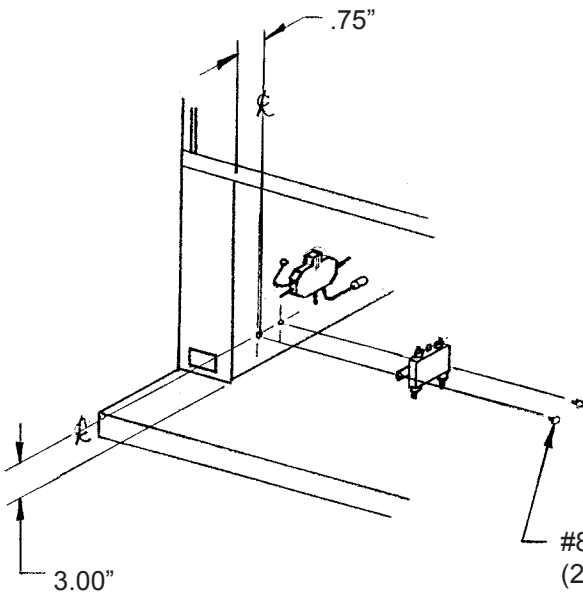

#8-32 x 3/8" Sems Screw (2) Req'd

**ANY QUESTIONS??? CONTACT ROYAL VENDORS' CUSTOMER SERVICE DEPARTMENT
CALL TOLL FREE (800) 931-9214**