



# SERVICE BULLETIN 338

426 Industrial Boulevard • Kearneysville WV 25430-2776 • USA  
 Telephone: +1 304 728 7056 • technicalinquiry@royalvenders.com  
 Toll-free in North America: 1 800 931 9214 • Fax: +1 304 725 4016  
 Canada: +1 905 738 5777 • Mexico: +52 55 5203 6887  
 Europe: +49 2158 95 1000 • Australia: +61 2 9890 5433

Page: 1 of 5

Date: 15 Dec 10

Revision: 00

**SUBJECT:** Narrow to Wide CDC Port Conversion Kit Installation

Number of  
People  
Required



**MODELS:** 804, 660

KIT NUMBER	KIT DESCRIPTION
352560	Narrow to Wide CDC Port Conversion Kit

**TOOLS REQUIRED:** Drill with Phillips-head driver, socket wrench with 7/16" (12 mm) socket

**ESTIMATED INSTALLATION TIME:** 25 minutes

**BULLETIN DESCRIPTION:** This bulletin explains the procedure for converting narrow port CDC venders to wide port.

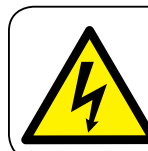

The following areas of this vender contain voltage which can cause serious injury or even death: the main power cord, supplying 115-230 VAC to the evaporator, EMI filter, and refrigeration system; the power line from the EMI filter to the ballast and transformer; and the ballast, which can produce upwards of 600 volts. Remove all power from the vender before working in any of these areas.

## INSTALLATION INSTRUCTIONS:

1. Remove power by unplugging the vender's power cord from the AC voltage source (wall outlet).
2. Remove the fluorescent bulbs from the vender's door.
3. Remove the coin chute from the door. (Refer to Figure 1.)
4. Remove the coin return cable. (Refer to Figure 2.) **Note:** This item will not be re-used, so it can be cut with wire cutters for removal.
5. Remove the existing changer vault and brace. (Refer to Figure 3.)
6. Remove the burst-open latch strike that is attached to the changer vault. Retain this part for later use. (Refer to Figure 4.)
7. Remove the coin box. Then, remove the coin box housing. (Refer to Figure 5.)
8. Remove the existing port assembly and brace. (Refer to Figure 6.)
9. Install the anti-theft plate in the new port assembly. (Refer to Figure 7.)
10. Attach the port brace to the new port assembly. (Refer to Figure 8.)
11. Install the coin cup in the new port assembly. (Refer to Figure 9.)
12. Attach the burst open latch strike to the port assembly.
13. Install the port assembly in the door. (Refer to Figure 10.)
14. Attach the changer vault brace to the changer vault assembly. (Refer to Figure 11.)
15. Install the changer vault assembly in the door. The tabs at the bottom of the changer vault should be inserted into the port brace. (Refer to Figure 12.) Secure the changer vault brace with two screws, one on each end, screwed into the chassis of the door.
16. Install the coin chute support bracket. (Refer to Figure 13.)
17. Re-install the coin chute assembly. Secure it to the support brackets with one screw each.
18. Install the new coin return cable.
19. Restore power by plugging the vender's power cord into the AC voltage source (wall outlet).

In an effort to provide our customers with the latest information on our equipment, Royal Vendors sends service bulletins to customers using the original ship-to address or e-mail addresses, if supplied by our customers. We also post all service bulletins on our website at www.royalvenders.com. If for any reason a vender is moved to another location or is sold to another customer other than to whom Royal Vendors originally sent the machine, it is the responsibility of the original purchaser of the vender to notify the appropriate personnel of the service bulletin.

**ANY QUESTIONS? CONTACT ROYAL VENDORS' CUSTOMER SERVICE DEPARTMENT  
IN NORTH AMERICA, CALL TOLL FREE 1 800 931 9214**



# SERVICE BULLETIN 338

426 Industrial Boulevard • Kearneysville WV 25430-2776 • USA  
Telephone: +1 304 728 7056 • technicalinquiry@royalvenders.com  
Toll-free in North America: 1 800 931 9214 • Fax: +1 304 725 4016  
Canada: +1 905 738 5777 • Mexico: +52 55 5203 6887  
Europe: +49 2158 95 1000 • Australia: +61 2 9890 5433

Page: 2 of 5

Date: 15 Dec 10

Revision: 00

**SUBJECT:** Narrow to Wide CDC Port Conversion Kit Installation

**MODELS:** 804, 660

**Figure 1.** Remove the coin chute from the door.

To remove the coin chute, first unscrew it from the support brackets. (Depending on the date of manufacture, these brackets may not exactly match the ones shown below, although the ones shown should be most common.)

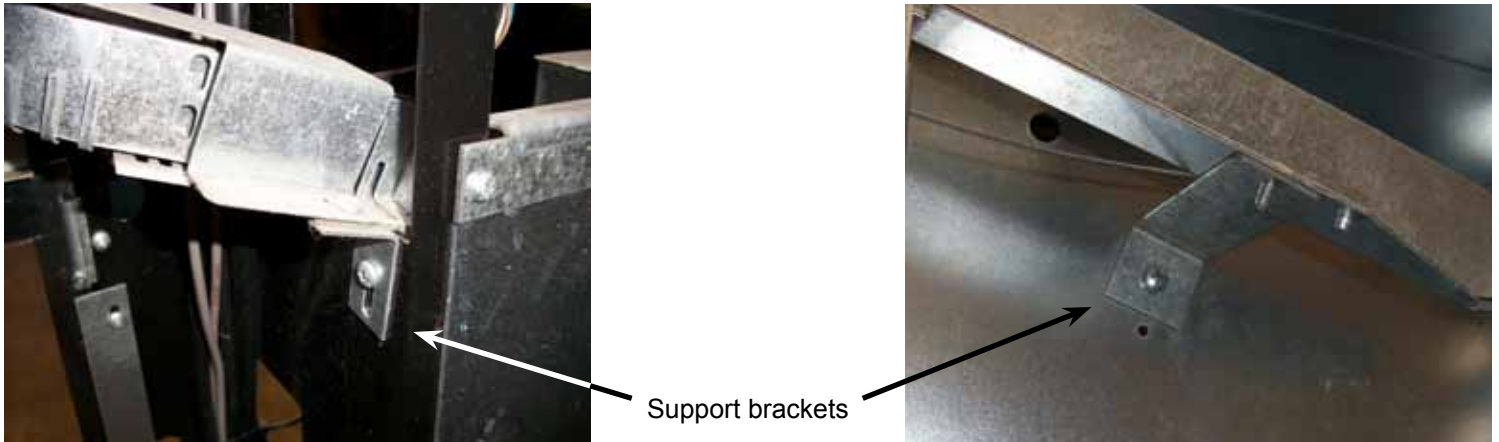

**Figure 2.** Remove the coin return cable.

Use wire-cutters to cut the coin return cable. Cut the cable in the loops at each end, then remove it from the vender.

Coin return cable

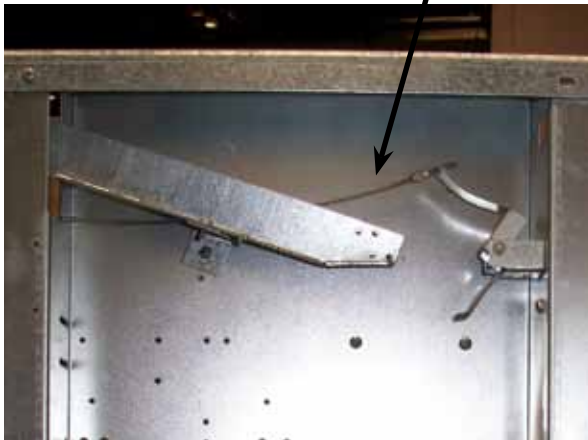

**Figure 3.** Remove the changer vault and brace.

Use a drill with Phillips-head bit to remove the six screws that secure the changer vault and brace. (The arrows below point to the screws that must be removed.) Remove these two items together as one assembly.



**ANY QUESTIONS? CONTACT ROYAL VENDORS' CUSTOMER SERVICE DEPARTMENT  
IN NORTH AMERICA, CALL TOLL FREE 1 800 931 9214**



# SERVICE BULLETIN 338

426 Industrial Boulevard • Kearneysville WV 25430-2776 • USA  
Telephone: +1 304 728 7056 • technicalinquiry@royalvendors.com  
Toll-free in North America: 1 800 931 9214 • Fax: +1 304 725 4016  
Canada: +1 905 738 5777 • Mexico: +52 55 5203 6887  
Europe: +49 2158 95 1000 • Australia: +61 2 9890 5433

Page: 3 of 5

Date: 15 Dec 10

Revision: 00

**SUBJECT:** Narrow to Wide CDC Port Conversion Kit Installation

**MODELS:** 804, 660

**Figure 4.** Remove the burst-open latch strike.

Use a drill with Phillips-head bit to remove the two screws that secure the strike. Retain this part for later use.

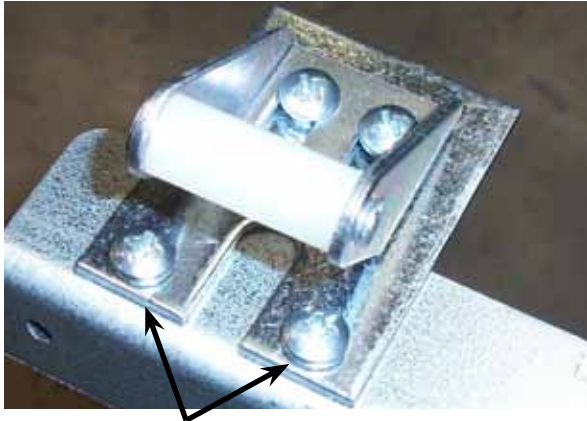

Remove these two screws

**Figure 5.** Remove the coin box and coin box housing.

Use a drill with Phillips-head bit to remove the four screws that secure the housing.

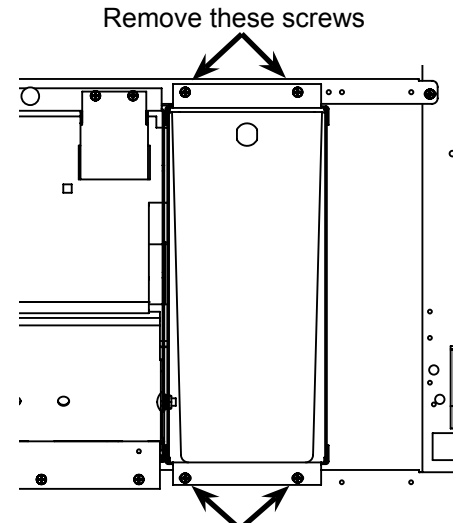

Remove these screws

**Figure 6.** Remove the port assembly and brace.

Use a drill with Phillips-head bit to remove the screws that secure the port assembly and brace. (The arrows below point to the screws that must be removed.) Remove these two items together as one assembly.

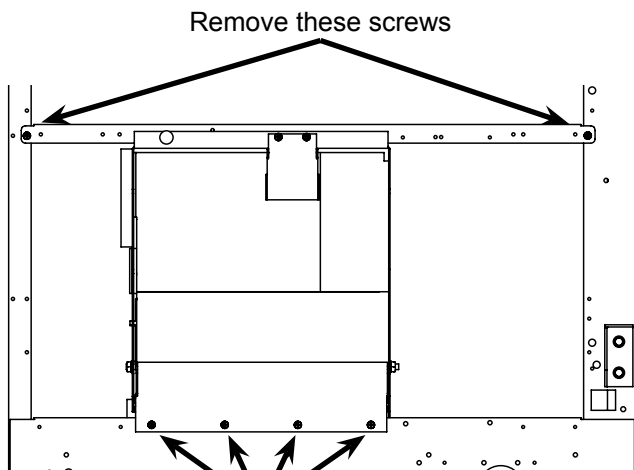

Remove these screws

**Figure 7.** Install the anti-theft bar.

Place the anti-theft bar in the port assembly. Install two carriage bolts to hold the bar in place (one on each side). Secure the bolts with two Keps nuts.

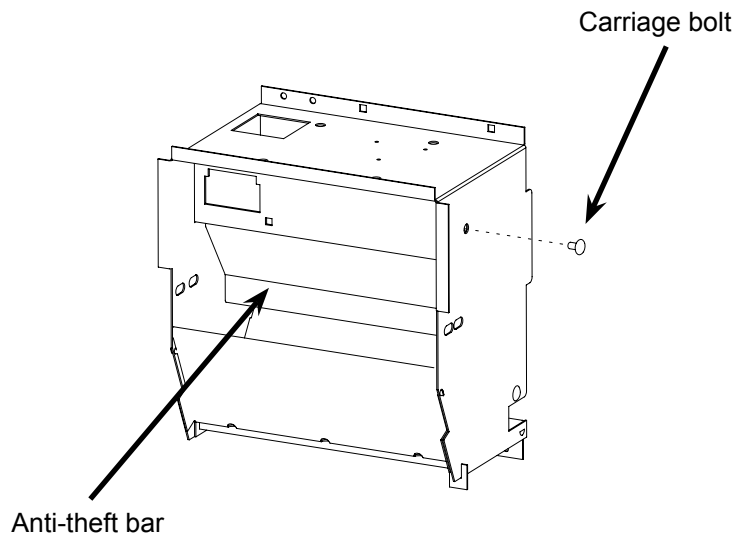

**ANY QUESTIONS? CONTACT ROYAL VENDORS' CUSTOMER SERVICE DEPARTMENT  
IN NORTH AMERICA, CALL TOLL FREE 1 800 931 9214**



# SERVICE BULLETIN 338

426 Industrial Boulevard • Kearneysville WV 25430-2776 • USA  
Telephone: +1 304 728 7056 • [technicalinquiry@royalvendors.com](mailto:technicalinquiry@royalvendors.com)  
Toll-free in North America: 1 800 931 9214 • Fax: +1 304 725 4016  
Canada: +1 905 738 5777 • Mexico: +52 55 5203 6887  
Europe: +49 2158 95 1000 • Australia: +61 2 9890 5433

Page: 4 of 5

Date: 15 Dec 10

Revision: 00

**SUBJECT:** Narrow to Wide CDC Port Conversion Kit Installation

**MODELS:** 804, 660

**Figure 8.** Attach the brace to the port assembly.

Secure the brace to the port assembly with two carriage bolts and two Keps nuts.

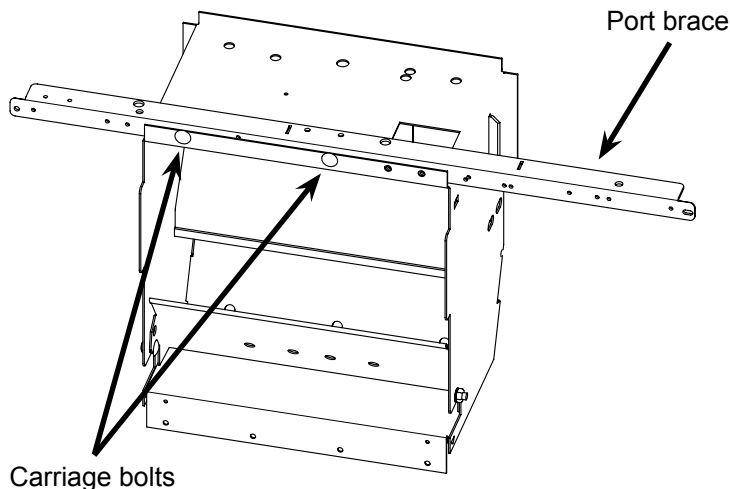

**Figure 9.** Install the coin cup.

The coin cup should be inserted through the anti-theft bar from the rear. Once the coin cup is installed, secure it with two screws from the kit.

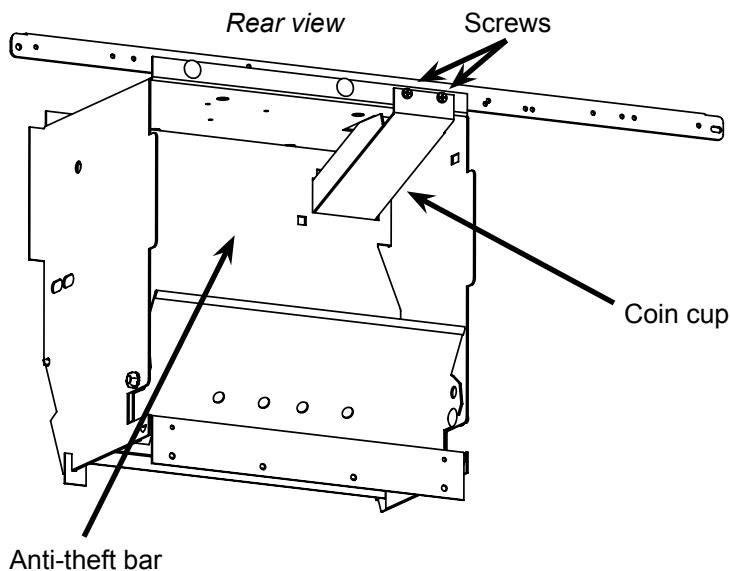

**Figure 10.** Install the new port assembly in the door.

Secure the port assembly with six screws from the kit as shown below.

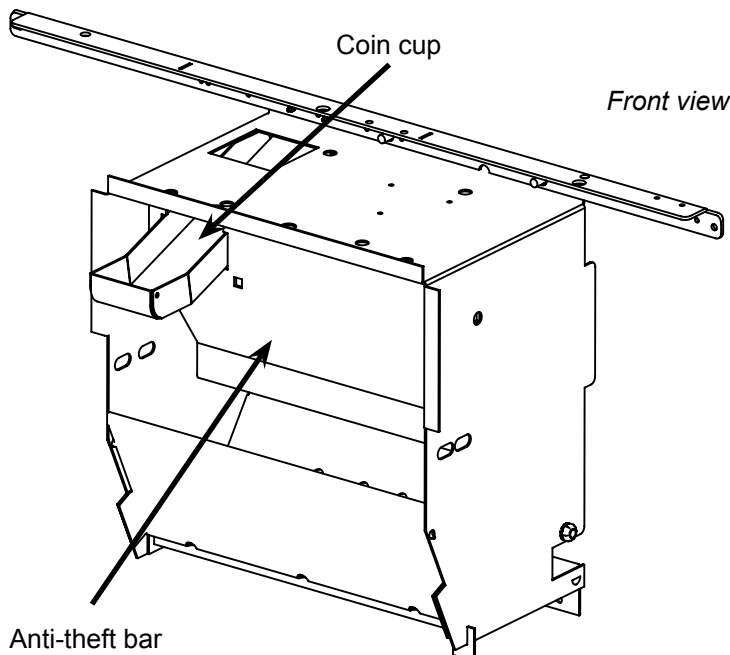
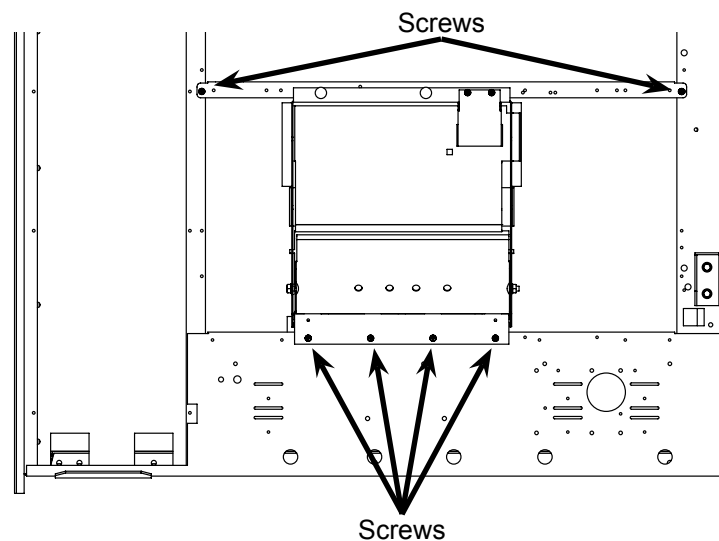

**ANY QUESTIONS? CONTACT ROYAL VENDORS' CUSTOMER SERVICE DEPARTMENT  
IN NORTH AMERICA, CALL TOLL FREE 1 800 931 9214**



# SERVICE BULLETIN 338

426 Industrial Boulevard • Kearneysville WV 25430-2776 • USA  
Telephone: +1 304 728 7056 • [technicalinquiry@royalvendors.com](mailto:technicalinquiry@royalvendors.com)  
Toll-free in North America: 1 800 931 9214 • Fax: +1 304 725 4016  
Canada: +1 905 738 5777 • Mexico: +52 55 5203 6887  
Europe: +49 2158 95 1000 • Australia: +61 2 9890 5433

Page: 5 of 5

Date: 15 Dec 10

Revision: 00

**SUBJECT:** Narrow to Wide CDC Port Conversion Kit Installation

**MODELS:** 804, 660

**Figure 11.** Install the changer vault brace.

Secure the brace to the changer vault with two screws.

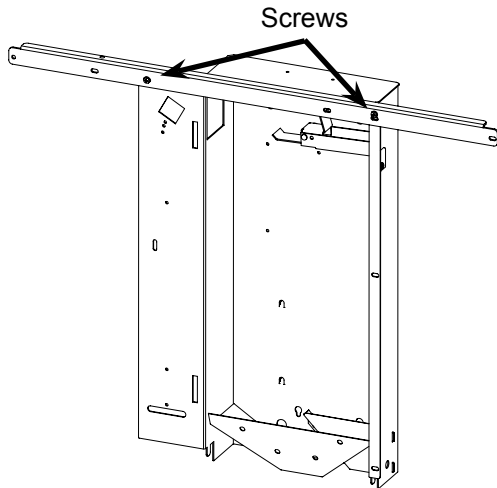

**Figure 12.** Install the changer vault in the door.

The tabs at the bottom of the changer vault assembly should be inserted into the port brace.

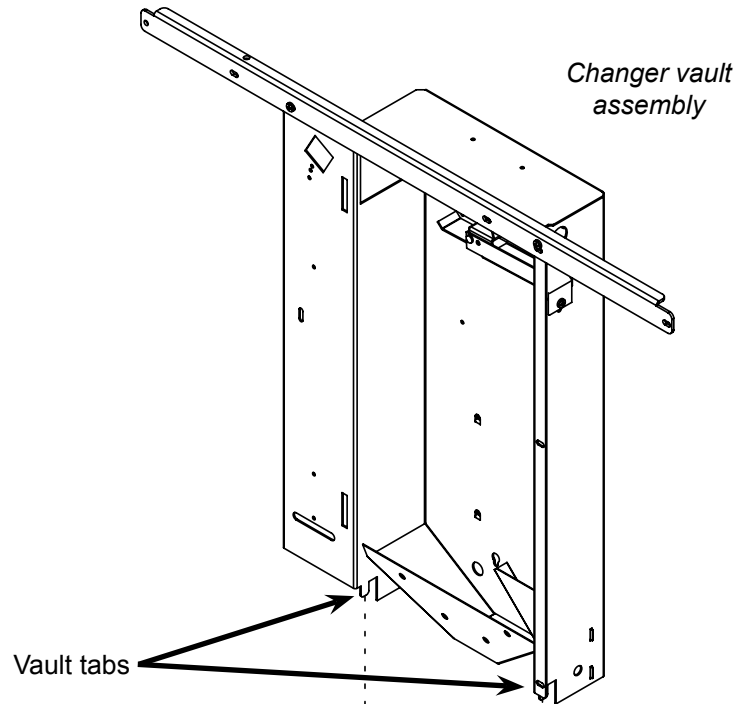

**Figure 13.** Install the coin chute support bracket.

Secure the bracket with one screw.

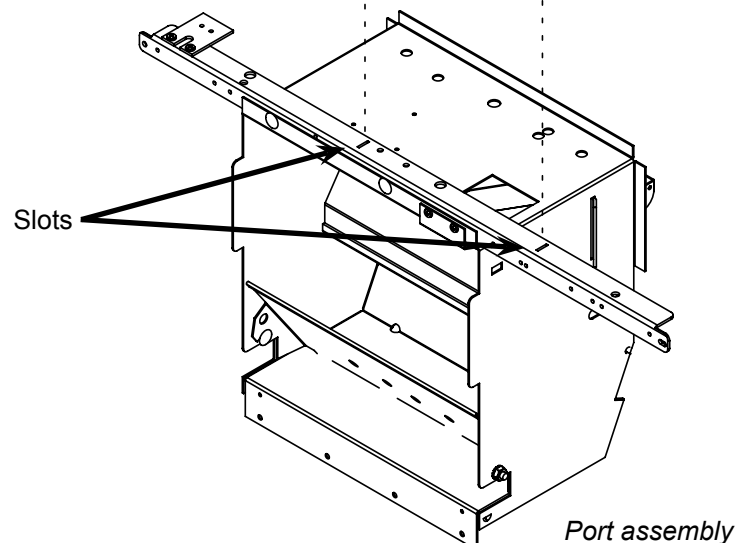
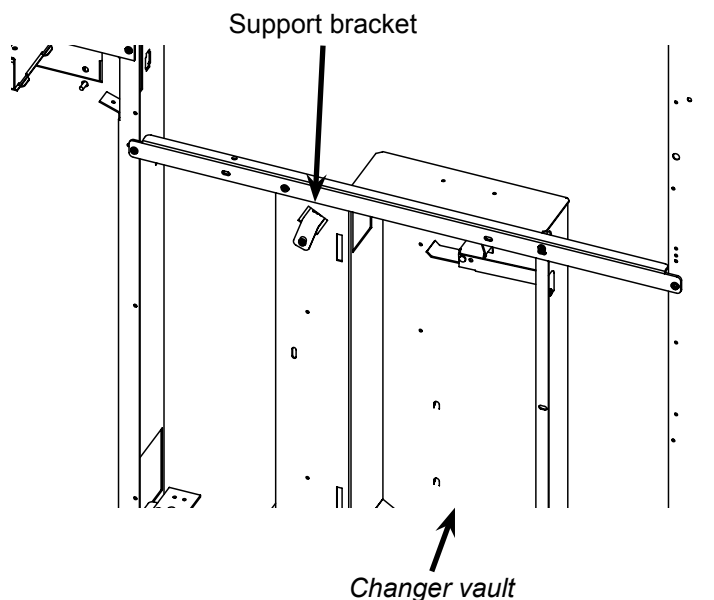

**ANY QUESTIONS? CONTACT ROYAL VENDORS' CUSTOMER SERVICE DEPARTMENT  
IN NORTH AMERICA, CALL TOLL FREE 1 800 931 9214**