



SERVICE BULLETIN # 00218

201 INDUSTRIAL BOULEVARD • KEARNEYSVILLE, WV 25430

Phone: (304) 728-7056 • Fax: (304) 725-6579 • Toll Free: (800) 931-9214

PAGE: 1 of 2

DATE: 2-19-01

REVISION: 00

SUBJECT: Small Package Vending Kit for the 20 Plus Vender

MODELS: 20 Plus

KIT NUMBER	KIT DESCRIPTION
296750	Small Package 20 Plus Kit, Front Column
296760	Small Package 20 Plus Kit, Rear Column

IMPORTANT NOTE: Kit cannot be used with columns 6 and 12

REASON FOR BULLETIN:

The 20 Plus vender is manufactured with a standard product stop which can vend an assortment of packages. The small-package product stop is broke a little different from standard product stops to reliably vend 2.5" diameter packages.

INSTRUCTIONS: *Note: It may be easier to install the new product stops if you remove the can chute*

FRONT COLUMN

1. Power down vender by removing the vender's main power cord from the wall outlet.
2. Remove product from column to be converted, as well as the column behind it.
3. Remove cover plate from front of vend rack assembly by removing the three screws and lifting the cover plate out.
4. Remove the black wire tie that holds the vend motor harness to the front product stop. Then remove the existing product stop from the column by pulling out the product stop holding rod.
5. Install new product stop in the same position as the old product stop, then insert rod.
6. Replace vend rack cover plate, and secure it with the screws.
7. Set front retainers to the sixth position, counting from the front.
8. Install right and left small package retainers (black can stops) by inserting tabs into the corresponding notches of the column divider (see figure 4). Once inserted, lift and pull out and down into extended position.
9. Restore power to the vender by plugging the main power cord back into the wall outlet.
10. Test vend to ensure reliability.

REAR COLUMN

1. Power down vender by removing the vender's main power cord from the wall outlet.
2. Remove product from column to be converted, as well as the column in front of it.
3. Remove cover plate from front of vend rack assembly by removing the three screws and lifting the cover plate out.
4. Remove the existing product stop from the column by pulling out the product stop holding rod.
5. Install new product stop in the same position as the old product stop, then insert rod.
6. Replace vend rack cover plate, and secure it with the screws.
7. Set rear column retainers to the sixth position, counting from the rear.
8. Restore power to the vender by plugging the main power cord back into the wall outlet.
9. Test vend to ensure reliability.

Small Package Front Product Stop

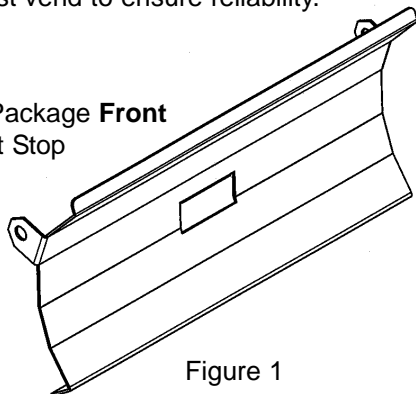
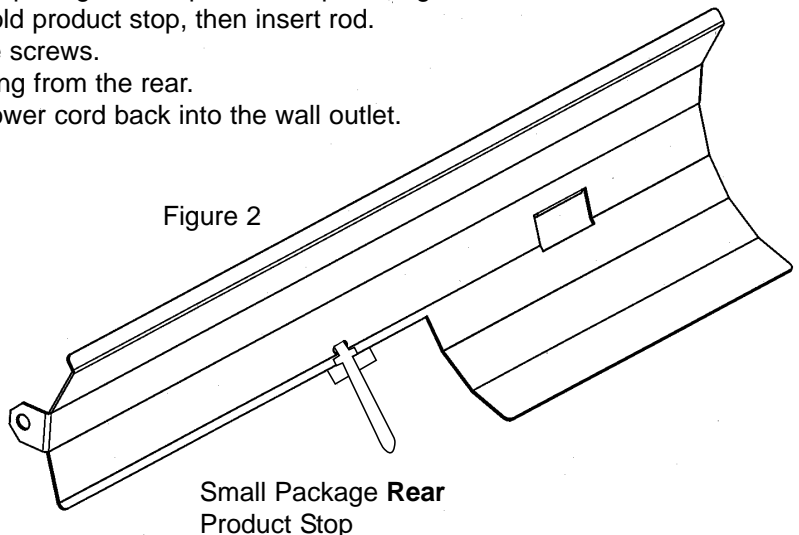

Figure 1

Figure 2



Small Package Rear Product Stop

ANY QUESTIONS??? CONTACT ROYAL VENDORS' CUSTOMER SERVICE DEPARTMENT
CALL TOLL FREE (800) 931-9214



SERVICE BULLETIN # 00218

201 INDUSTRIAL BOULEVARD • KEARNEYSVILLE, WV 25430
Phone: (304) 728-7056 • Fax: (304) 725-6579 • Toll Free: (800) 931-9214

PAGE: 2 of 2
DATE: 2-19-01
REVISION: 00

SUBJECT: Small Package Vending Kit for the 20 Plus Vender

MODELS: 20 Plus

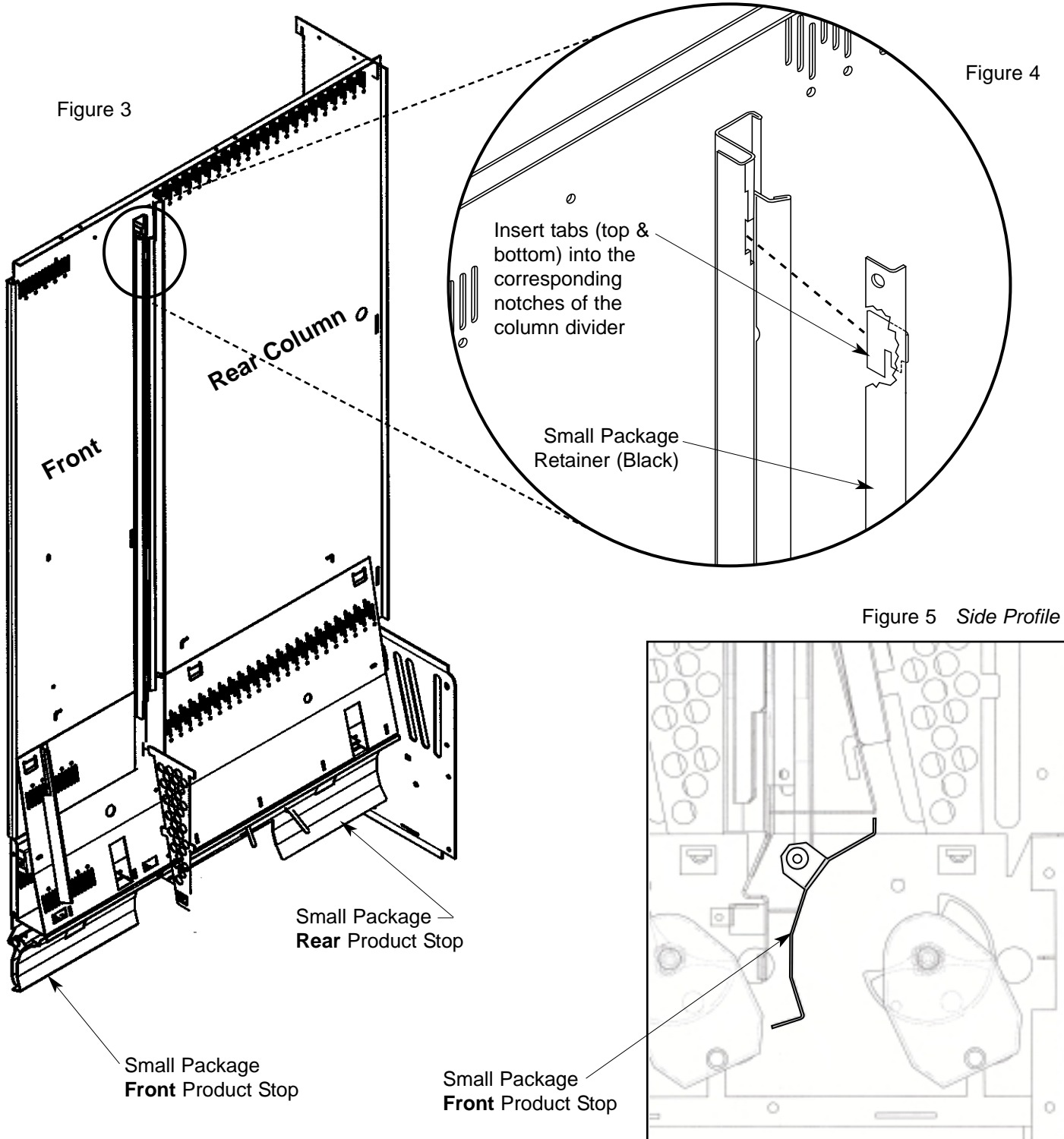

ANY QUESTIONS??? CONTACT ROYAL VENDORS' CUSTOMER SERVICE DEPARTMENT
CALL TOLL FREE (800) 931-9214