



SERVICE BULLETIN # 00212

201 INDUSTRIAL BOULEVARD • KEARNEYSVILLE, WV 25430

Phone: (304) 728-7056 • Fax: (304) 725-6579 • Toll Free: (800) 931-9214

PAGE: 1 of 1

DATE: 10-10-01

REVISION: 01

SUBJECT: Installation of a T-Handle Cover Kit

MODELS: All CDC Venders

of People
Required



KIT NUMBER

KIT DESCRIPTION

303170

T-Handle Cover Kit CDC

Tools Required: Phillips Screwdriver

Estimated Installation Time: 5 Minutes

REASON FOR BULLETIN: To add extra protection to the T-handle by enclosing the T-handle housing.

INSTALLATION INSTRUCTIONS:

1. Remove power from the vender by unplugging the vender's main power cord from the AC voltage power source.
2. Remove the existing T-handle cover. Also remove the rubber grommet on the T-handle stud.
3. Assemble the new T-handle cover plate. Secure the two parts together using one of the #6-32 screws. (see Figure A)
4. Slide the new T-handle cover plate over the T-handle stud. Secure the left side with one #6-32 screw. Secure the right side with the two #8-32 screws. (see Figure B)
5. Replace the rubber grommet on the T-handle stud.
6. Restore power to the vender by plugging in the vender's main power cord to the AC voltage power source.

Figure A

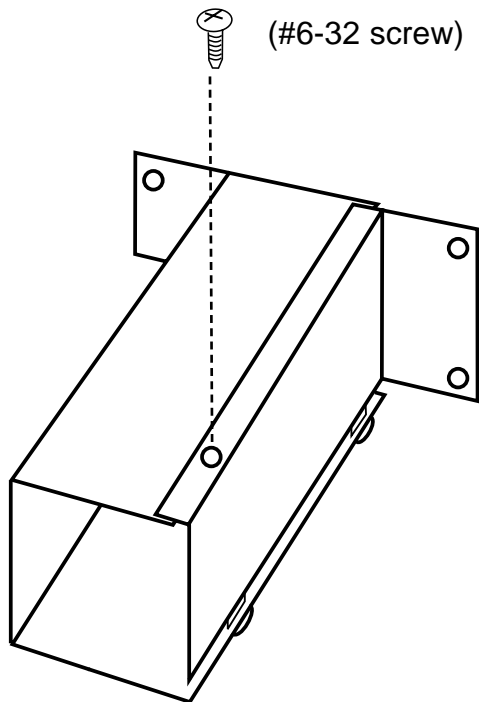
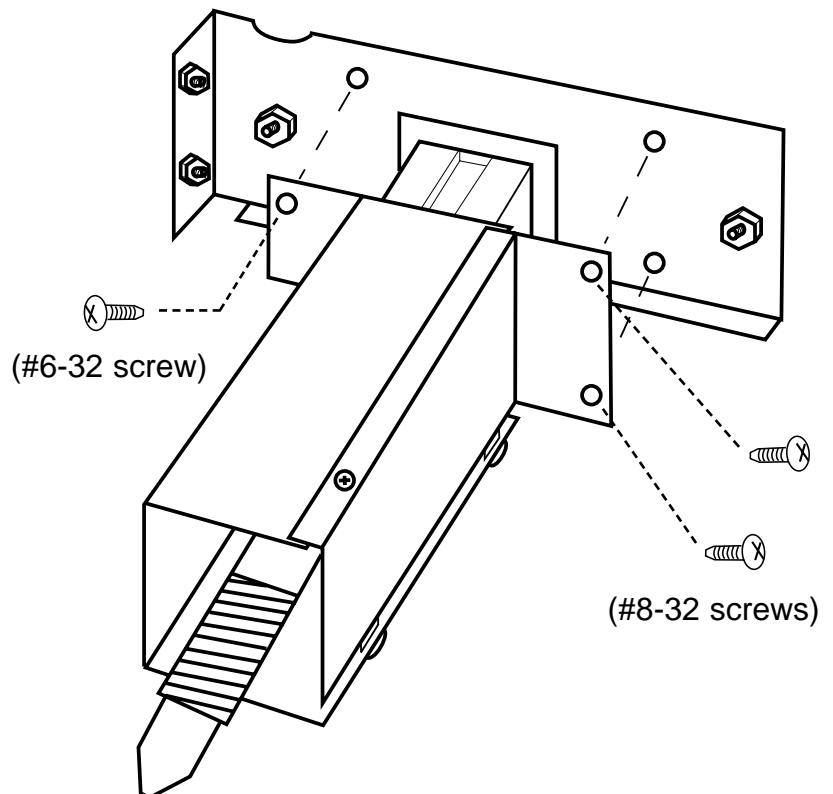

Figure B



ANY QUESTIONS??? CONTACT ROYAL VENDORS' CUSTOMER SERVICE DEPARTMENT
CALL TOLL FREE (800) 931-9214