



# SERVICE BULLETIN # 00199

201 INDUSTRIAL BOULEVARD • KEARNEYSVILLE, WV 25430

Phone: (304) 728-7056 • Fax: (304) 725-6579 • Toll Free: (800) 931-9214

PAGE: 1 of 2

DATE: 6-20-00

REVISION: 01

**SUBJECT:** Enclosed Coin Cup

**MODELS:** MIV, GIII Landscape CDC Venders

KIT NUMBER	KIT DESCRIPTION
231575	Enclosed Coin Cup Kit for Coke Narrow Port
303140	Enclosed Coin Cup Kit for Coke Wide Port
303150	Enclosed Coin Cup Kit for Pepsi/Cold Drink Wide Port

## Instructions for Narrow Port:

### TOOLS REQUIRED

7/16 Socket Wrench  
Phillips Screw Driver

1. Power down vender.
2. Remove the left fluorescent bulb from the vender.
3. Remove the two screws holding the coin cup and then remove the coin cup.
4. Remove the nut on the left side of the port holding the anti-theft plate, then remove the anti-theft plate.
5. Remove the four nuts (2 on the left, and 2 on the right) holding the can stop, then remove the can stop.
6. From the back of the port, install the new anti-theft plate by sliding the angled end into the slot on the right side of the port body. Fasten the left end to the left inside wall of the port using the hardware removed earlier.
7. Slide the new can stop/coin-cup assembly into the slots where the old can-stop was located. Push it inward until the coin-cup assembly contacts the anti-theft plate.
8. Fasten the coin-cup assembly to the anti-theft plate with the ¼-20 x ½" hardware provided.
9. Fasten the can stop to the sides of the port body with four ¼-20 carriage bolts and 4 1/4-20 nuts.
10. Slide the new coin-cup ramp into the hole in the anti-theft plate and tighten down with the two screws from the old coin cup.
11. Insert the left fluorescent bulb back in the vender.

**Note:** Two additional carriage bolts (black) are provided in the kit, and can be substituted for the bolts that secure the right flange of the can stop.

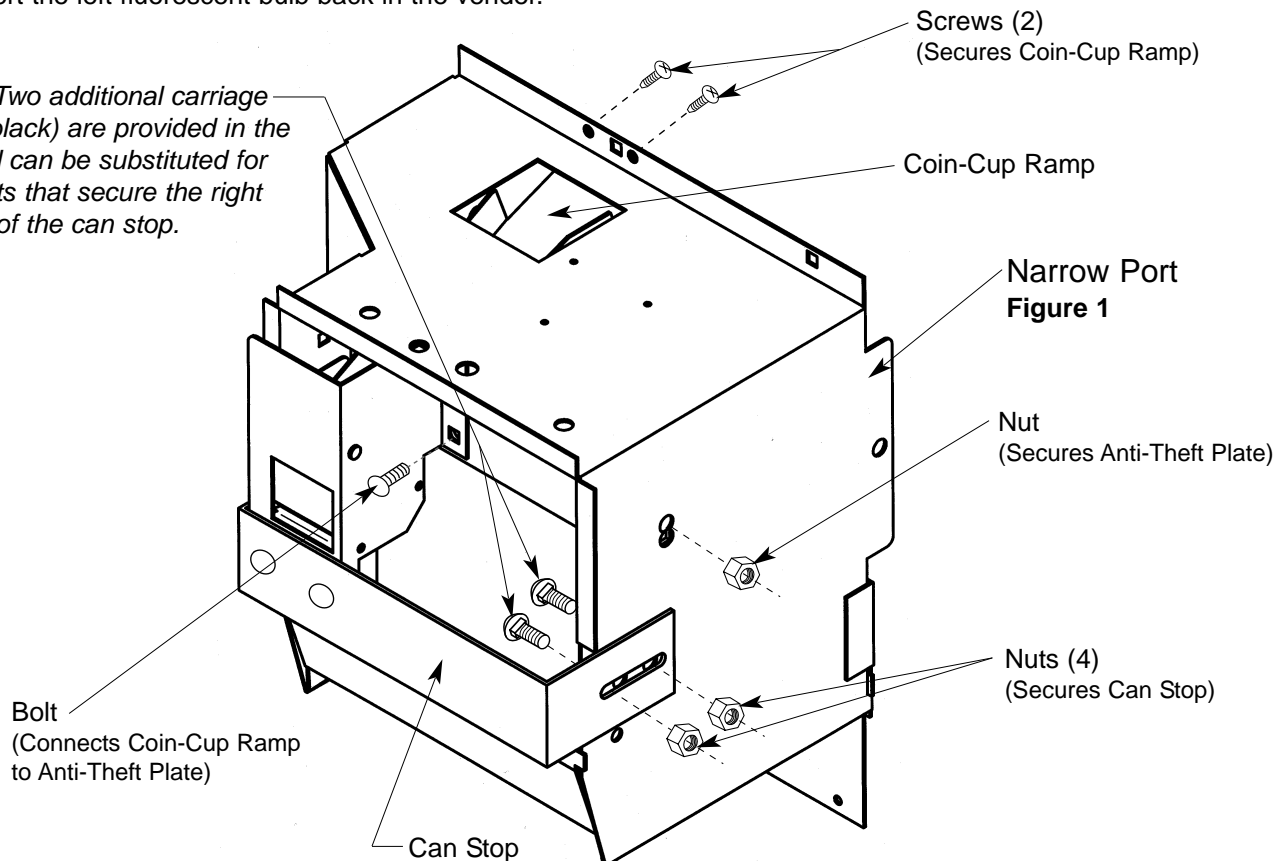

**ANY QUESTIONS???** CONTACT ROYAL VENDORS' CUSTOMER SERVICE DEPARTMENT  
CALL TOLL FREE (800) 931-9214



# SERVICE BULLETIN # 00199

201 INDUSTRIAL BOULEVARD • KEARNEYSVILLE, WV 25430  
Phone: (304) 728-7056 • Fax: (304) 725-6579 • Toll Free: (800) 931-9214

PAGE: 2 of 2
DATE: 6-20-00
REVISION: 01

**SUBJECT:** Enclosed Coin Cup

**MODELS:** MIV, GIII Landscape CDC Venders

## Instructions for Wide Port:

1. Power down vender.
2. Remove the left fluorescent bulb from the vender.
3. Remove the two screws holding the coin cup and then remove the coin cup.
4. Remove the nut on the left side of the port holding the anti-theft plate, then remove the anti-theft plate.
5. Remove the four nuts (2 on the left, and 2 on the right) holding the can stop, then remove the can stop.
6. From the back of the port, install the new anti-theft plate by sliding the angled end into the slot on the right side of the port body. Fasten the left end to the left inside wall of the port using the hardware removed earlier.
7. Slide the new can stop/coin-cup assembly into the slots where the old can-stop was located. Push it inward until the coin-cup assembly contacts the anti-theft plate.
8. Fasten the two flanges on the coin-cup to the anti-theft plate and port body using two ¼-20 x ½" carriage bolts..
9. Fasten the can stop to the sides of the port body with four ¼-20 carriage bolts and 4 1/4-20 nuts.
10. Slide the new coin-cup ramp into the hole in the anti-theft plate and tighten down with the two screws from the old coin cup.
11. Insert the left fluorescent bulb back in the vender.

**Note:** Two additional carriage bolts (black) are provided in the kit, and can be substituted for the bolts that secure the right flange of the can stop.

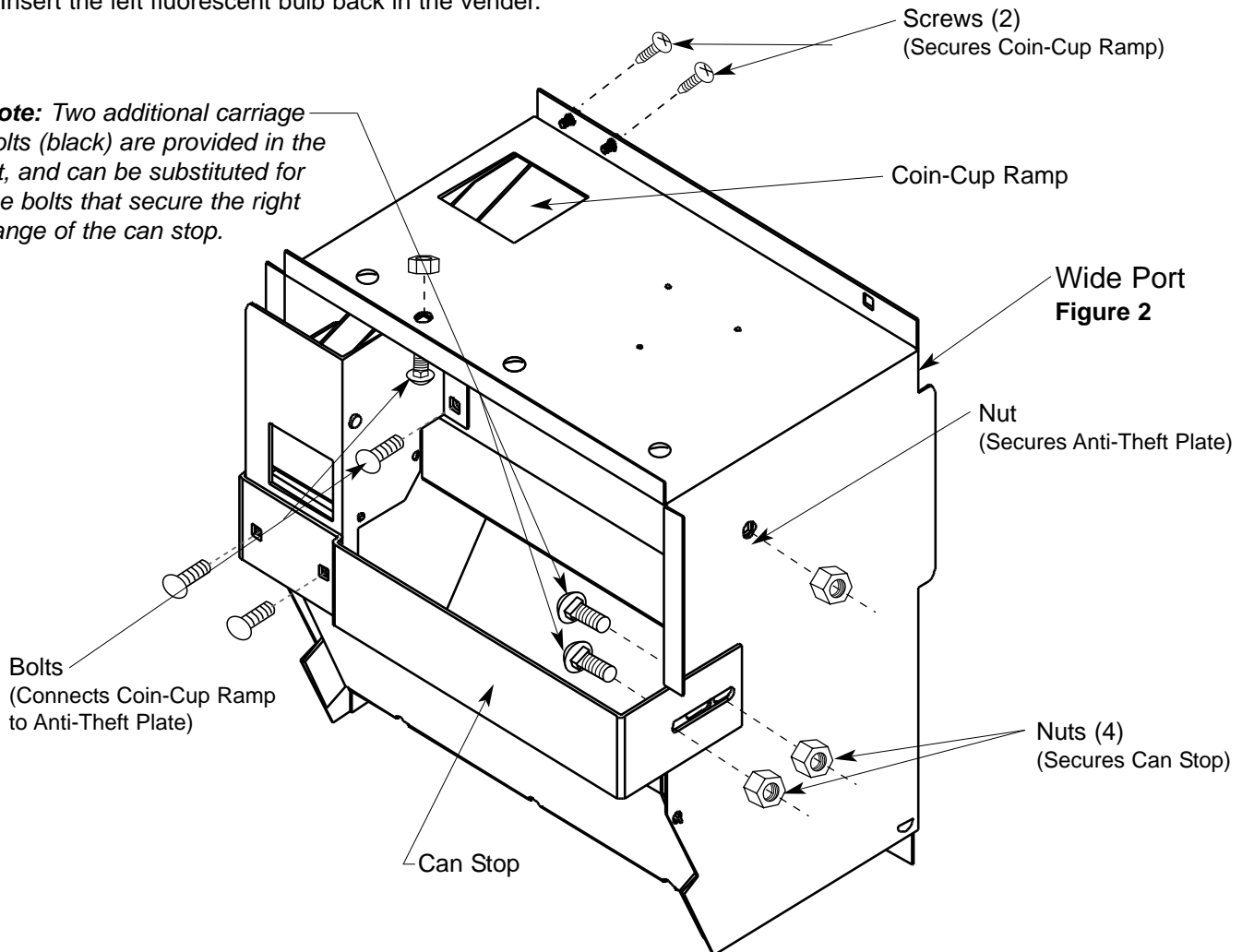

**ANY QUESTIONS???** CONTACT ROYAL VENDORS' CUSTOMER SERVICE DEPARTMENT  
CALL TOLL FREE (800) 931-9214