

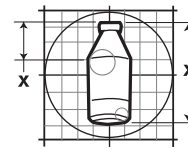

162 Package Vending Specification

426 Industrial Boulevard • Kearneysville WV 25430-2776 • USA
 Telephone: +1 304 728 7056 • technicalinquiry@royalvenders.com
 Toll-free in North America: 1 800 931 9214 • Fax: +1 304 725 4016
 Canada: +1 905 738 5777 • Mexico: +52 55 5203 6887
 Europe: +49 2158 95 1000 • Australia: +61 2 9890 5433



Page: 1 of 3
Date: 13 Oct 09
Revision: 00

PRODUCT NAME: 250 mL Coca-Cola Contour aluminum bottle
BOTTLER / COMPANY: The Coca-Cola Company
VOLUME: 8.5 oz. / 250 mL
HEIGHT: 7.36 in. / 186.8 mm
WEIGHT: 0.70 lbs. / 0.32 kg
PACKAGE TYPE: PET
DIAMETER: 2.09 in. / 53.0 mm
COUNTRY OF ORIGIN: USA



APPROVED VENDERS

VENDER	RETAINERS		79" CAPACITY	
	Front	Rear	Front	Rear
GIII	10	6	36	36

KITS / PARTS

Kit Number	Kit Description
232059	72" 250 mL Contour Kit, Front Column
232060	72" 250 mL Contour Kit, Rear Column
231043	79" 250 mL Contour Kit, Front Column
231044	79" 250 mL Contour Kit, Rear Column

INSTALLATION INSTRUCTIONS

Note: Before working on vender, always remove power by unplugging the vender's main power cord from the AC voltage source (outlet).

Figure 1

INSTALLING THE 250 ML PRODUCT STOP AND MOVING SPACERS

1. Remove existing product from all columns to be converted.
2. Remove product stops currently in use for each column to be converted.
3. The setup for both front and rear columns is shown in Figures 1 and 3. Add spacers and stops in the following order (front to rear):

- A. 0.50" (13 mm) spacer
- B. 1.25" (32 mm) spacer
- C. Long standard product stop
- D. 250 mL product stop
- E. 0.72" (18 mm) spacer
- F. 0.72" (18 mm) spacer
- G. 250 mL product stop
- H. Long standard product stop
- I. 1.25" (32 mm) spacer
- J. 1.00" (25 mm) spacer

Note: The anti-tilt spring is not used with this kit and should be removed.

4. While adjusting the product stops, remove the black anti-rotation pawl from each column that is to be converted.

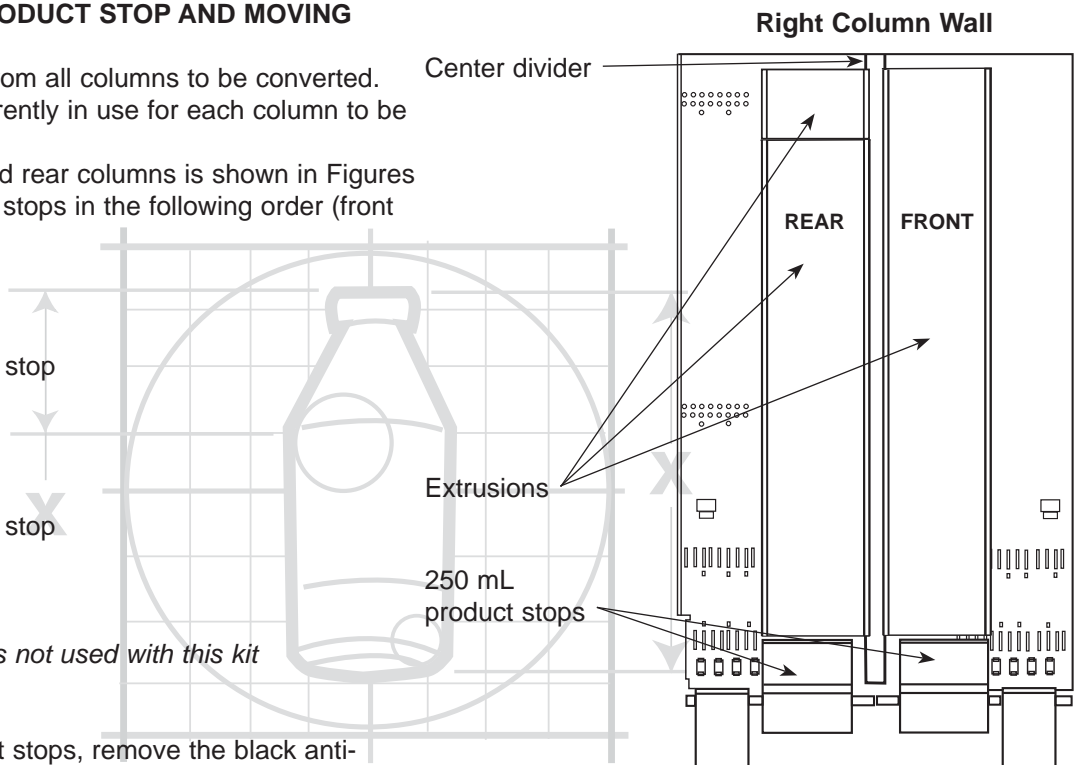

**ANY QUESTIONS? CONTACT ROYAL VENDORS' CUSTOMER SERVICE DEPARTMENT
 IN NORTH AMERICA, CALL TOLL FREE 1 800 931 9214**



162 Package Vending Specification

426 Industrial Boulevard • Kearneysville WV 25430-2776 • USA
Telephone: +1 304 728 7056 • technicalinquiry@royalvenders.com
Toll-free in North America: 1 800 931 9214 • Fax: +1 304 725 4016
Canada: +1 905 738 5777 • Mexico: +52 55 5203 6887
Europe: +49 2158 95 1000 • Australia: +61 2 9890 5433

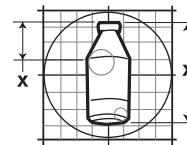

PRODUCT NAME: 250 mL Coca-Cola Contour aluminum bottle

INSTALLING THE PLASTIC COLUMN WALL EXTRUSIONS

The rear columns will have two extrusions instead of one. This is to allow sufficient clearance to install the longer extrusion. The front extrusion is sized to run the entire height of the column.

1. The clip that runs along the outside of the extrusion is designed to engage either flange of the center divider channel. When fully engaged, it will snap past the hem at the leading edge of the channel's flange, providing a secure connection to the channel.
2. Once clipped into place, the extrusions should be slid downward so they rest on top of the new 250 mL product stops.
3. Extrusion kits can be installed singularly or in pairs within the same column bay.
4. In rear columns, the small extrusion extension should be installed above the longer extrusion.
5. Adjust the retainers, and the vender is ready to use.

ADJUSTING PRODUCT RETAINERS

The procedure for adjusting the product retainers is different depending upon when the vender was built.

GIII, 1503 AND BEFORE:

1. In the rear columns, use the standard rear retainer assembly (backspacer). With the shim kit installed, slide the retainer forward as far as it will go, and engage the spring fingers on the right side into the partition wall at position 9. Next, swing the left side of the retainer assembly forward so that the fingers on its left side engage the next pair of holes in the left column wall at position 10 (one position closer to the front of the vender). It is very important that the retainer be angled forward on the left side to prevent cans from catching on the lip of the plastic extrusion as they approach the gate (pivot).
2. Place the front retainer in position 10 for the front column.

GIII, 1504 AND AFTER:

1. The column walls are punched to accept front retainers in both the front and rear columns; therefore, additional front retainers may be used as retainers for the rear columns. When a rear column is outfitted with a 250 mL shim kit, place a front retainer in position 10. The rear retainer assembly (backspacer) can be pushed all the way to the rear of the vender, where it is out of the way.
2. Place the front retainer in position 10 for the front column.

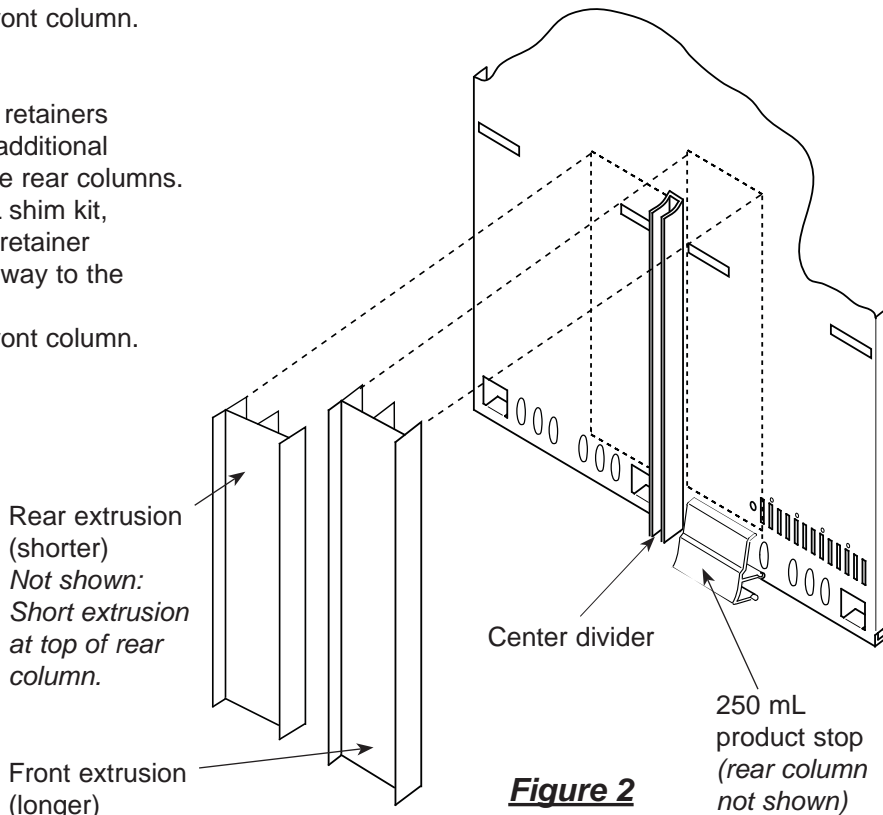

Figure 2

**ANY QUESTIONS? CONTACT ROYAL VENDORS' CUSTOMER SERVICE DEPARTMENT
IN NORTH AMERICA, CALL TOLL FREE 1 800 931 9214**



162 Package Vending Specification

426 Industrial Boulevard • Kearneysville WV 25430-2776 • USA
 Telephone: +1 304 728 7056 • technicalinquiry@royalvendors.com
 Toll-free in North America: 1 800 931 9214 • Fax: +1 304 725 4016
 Canada: +1 905 738 5777 • Mexico: +52 55 5203 6887
 Europe: +49 2158 95 1000 • Australia: +61 2 9890 5433

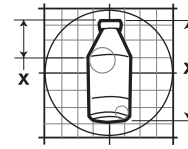

PRODUCT NAME: 250 mL Coca-Cola Contour aluminum bottle

Figure 3

ORDER OF SPACERS AND PRODUCT STOPS FOR FRONT AND REAR COLUMNS

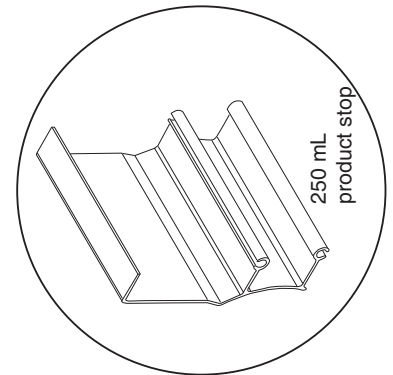
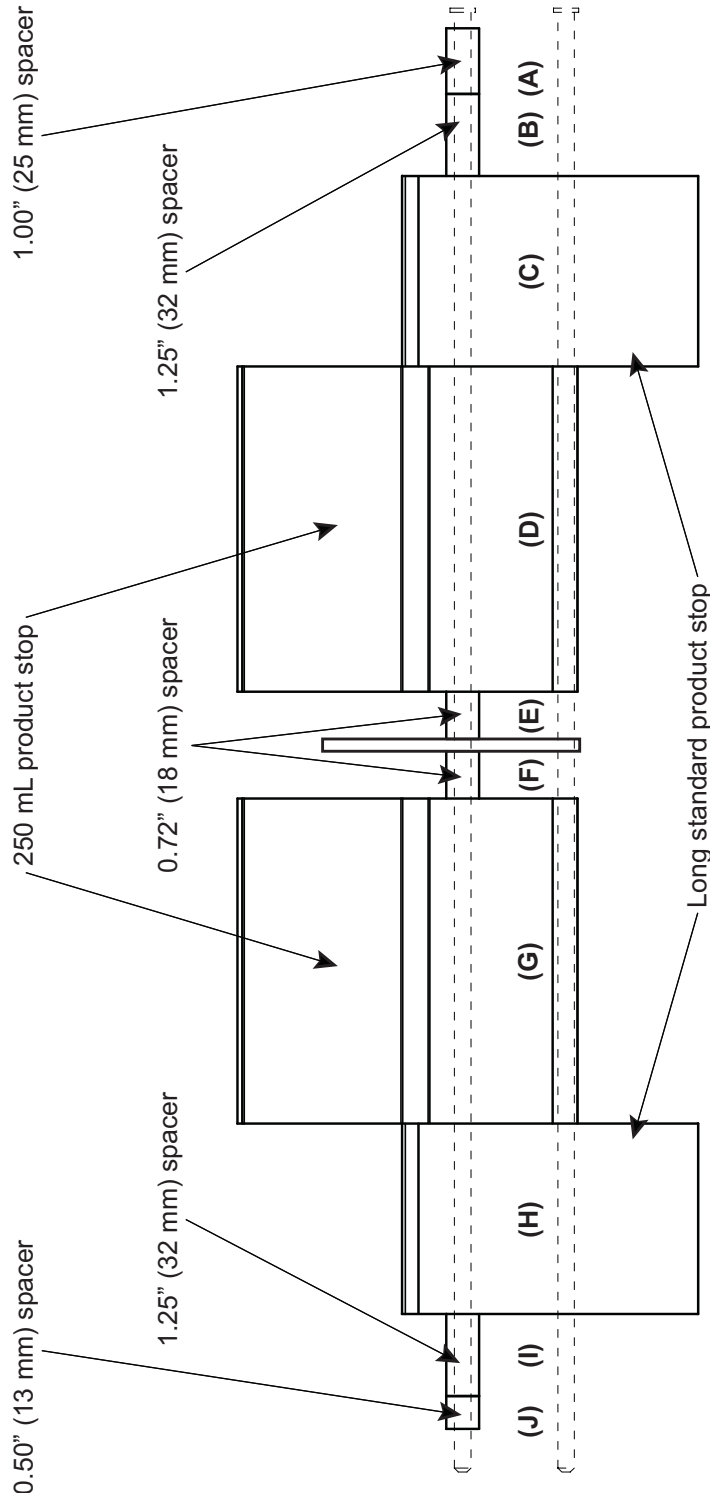

FRONT

REAR

**ANY QUESTIONS? CONTACT ROYAL VENDORS' CUSTOMER SERVICE DEPARTMENT
 IN NORTH AMERICA, CALL TOLL FREE 1 800 931 9214**