



SERVICE BULLETIN # 00144

201 INDUSTRIAL BOULEVARD • KEARNEYSVILLE, WV 25430

Phone: (304) 728-7056 • Fax: (304) 725-6579 • Toll Free: (800) 931-9214

PAGE: 1 of 7

DATE: 10-24-01

REVISION: 04

SUBJECT: Small Package Vending in GIII Venders

MODELS: GIII Venders

BEFORE WORKING ON VENDER: Remove power from vender by unplugging vender's main power cord from the AC voltage power source (wall outlet).

To Locate the proper kit and installation instructions for the package that you desire to vend:

1. Use Table #1 to locate the package that you desire to vend, then locate the serial number that applies to your vender(s). Refer to the "USE" column to find whether your application is a front column or rear. Then find the kit number in the "KIT #" column and lastly use the "Refer To" column to find the proper installation instructions on the following pages.
2. Use Table #2 to adjust your front product retainers, backspacers and adjustable product stops for the type of package you intend to use.

PACKAGE	RUN #	USE	KIT #	DESCRIPTION	REFER:
Powerade 20 oz. PLB	Prior to run 1379	1 per Front Col.	210750	Front Pivot, S/A	A
Powerade 20 oz. PLB	Prior to run 1379	1 per Rear Col.*	210760	Rear Pivot, S/A	A
Powerade 20 oz. PLB	After run 1379	Any Column	Factory capable	Factory capable	---
Evian, Naya 16.9 oz	Prior to run 1379	72" Front Col.	211740	Extrusion Kit, 72" GIII✓	A,B,D,E
Evian, Naya 16.9 oz	Runs 1379 to 1463 including run 1465 & 1467	72" Front Col.	211720	Extrusion Kit, 72" GIII	B,C,E
Evian, Naya 16.9 oz	Runs 1464 and higher	72" Front Col.	211725	Extrusion Kit, 72" GIII✗	C,E,F
Evian, Naya 16.9 oz	Prior to Run 1379	72" Rear Col.*	211750	Extrusion Kit, 72" GIII✓	A,B,D,E
Evian, Naya 16.9 oz	Runs 1379 and higher	72" Rear Col.	211730	Extrusion Kit, 72" GIII	B,C,E
Evian, Naya 16.9 oz.	Prior to run 1379	79" Front Col.	210790	Extrusion Kit, 79" GIII✓	A,B,D,E
Evian, Naya 16.9 oz	Runs 1379 to 1463 including run 1465 & 1467	79" Front Col.	210770	Extrusion Kit, 79" GIII	B,C,E
Evian, Naya 16.9 oz	Runs 1464 and higher	79" Front Col.	210775	Extrusion Kit, 79" GIII✗	C,E,F
Evian, Naya 16.9 oz	Prior to run 1379	79" Rear Col.*	210795	Extrusion Kit, 79" GIII✓	A,B,D,E
Evian, Naya 16.9 oz	Runs 1379 and higher	79" Rear Col.	210780	Extrusion Kit, 79" GIII	B,C,E

KIT NOTE: (✓) Denotes that kit also includes the "Pivot Assembly" necessary to vend Powerade.
 (✗) Run 1464 and after will use the new Front Retainer Extension, Except Runs 1465 & 1467.

IMPORTANT NOTES: 1. (*) This kit can not be used in Column 12.
 2. The run number is the first four digits of the Serial Number. (Example: 1464XX-XXXX)

Package / Size	Retainers (Front Column)	Backspacers (Rear Column)	Product Stop Setting
Powerade 20 oz PLB	#8 Slot (From Front)	#5 Hole (From Rear)	Bottle Setting (Left Hole)
Evian 16.9 oz (500 ml.)	#6 Slot (From Front)	#3 Hole (From Rear)	Can Setting (Right Hole)
Naya 16.9 oz (500 ml.)	#6 Slot (From Front)	#3 Hole (From Rear)	Can Setting (Right Hole)

ANY QUESTIONS??? CONTACT ROYAL VENDORS' CUSTOMER SERVICE DEPARTMENT
 CALL TOLL FREE (800) 931-9214



SERVICE BULLETIN # 00144

201 INDUSTRIAL BOULEVARD • KEARNEYSVILLE, WV 25430
Phone: (304) 728-7056 • Fax: (304) 725-6579 • Toll Free: (800) 931-9214

PAGE: 2 of 7
DATE: 10-24-01
REVISION: 04

SUBJECT: Small Package Vending in GIII Venders

MODELS: GIII Venders

IMPORTANT NOTE: The settings listed above in table #2 may not be listed in your vender. You may want to make note of them on your inner door decal for adjustments & settings.

NOTE: For additional information on similar packages concerning kit numbers and necessary adjustments please contact your local Royal Vendors distributor. For instructions of how to adjust your front product retainers, backspacers and adjustable product stops please refer to the venders inner door decal or operation & service manual.

INSTALLATION PROCEDURE "A"

REPLACE "SMALL" PRODUCT PIVOTS WITH "LARGE" PRODUCT PIVOTS (See Figure 1)

1. Remove all product from any column desired to be converted. It will also be necessary to remove all product from any joining front or rear column.
2. Loosen the Phillips head screw that fastens the rod retainer to the front of the base. Rotate the rod retainer to expose the head of the product pivot rod (See Figure 5).
3. While supporting the rear pivot, pull the product pivot rod straight out until the end of the rod just clears the front of the rear pivot. Remove the rear pivot.
4. While supporting the front pivot, pull the product pivot rod completely out. Remove the front pivot.
5. Place the correct pivot assembly, "Larger" one if desired, in the front column and insert the product pivot rod through the front base plate and through the product pivot and center support.
6. Place the correct pivot assembly, "Larger" one if desired, in the rear column and continue pressing the product pivot rod through the rear product pivot and through the rear base plate.
7. Attach the rod retainer to the front base that was removed in step #1.

Note: Make sure that the Pivot Pawl is reset into the proper position. See Figure 1-A (next page)

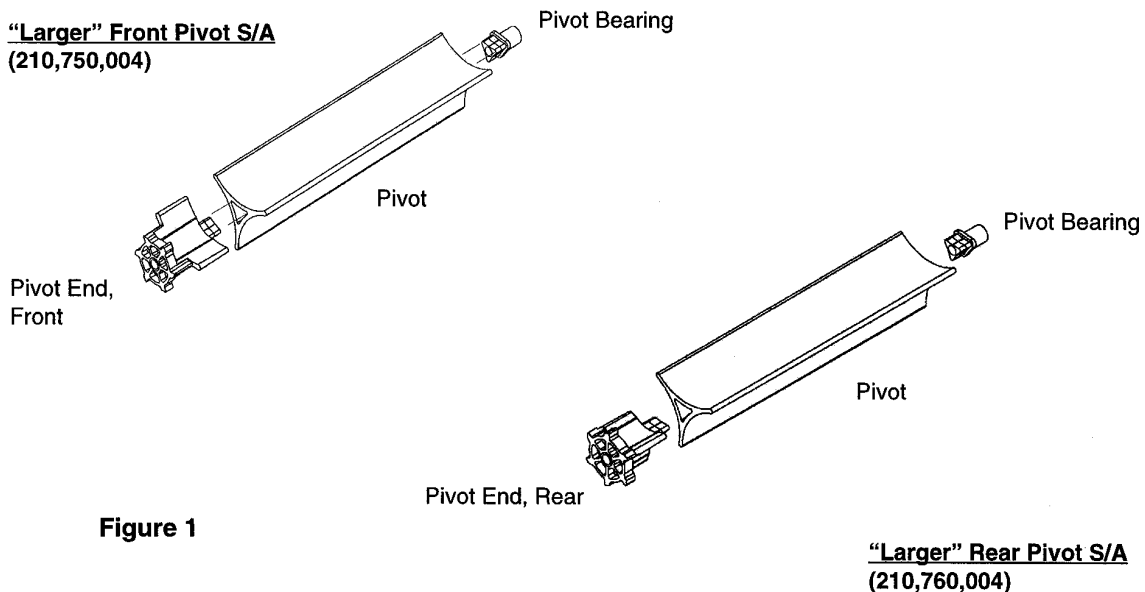

Figure 1

**ANY QUESTIONS??? CONTACT ROYAL VENDORS' CUSTOMER SERVICE DEPARTMENT
CALL TOLL FREE (800) 931-9214**



SERVICE BULLETIN # 00144

201 INDUSTRIAL BOULEVARD • KEARNEYSVILLE, WV 25430
Phone: (304) 728-7056 • Fax: (304) 725-6579 • Toll Free: (800) 931-9214

PAGE: 3 of 7
DATE: 10-24-01
REVISION: 04

SUBJECT: Small Package Vending in GIII Venders

MODELS: GIII Venders

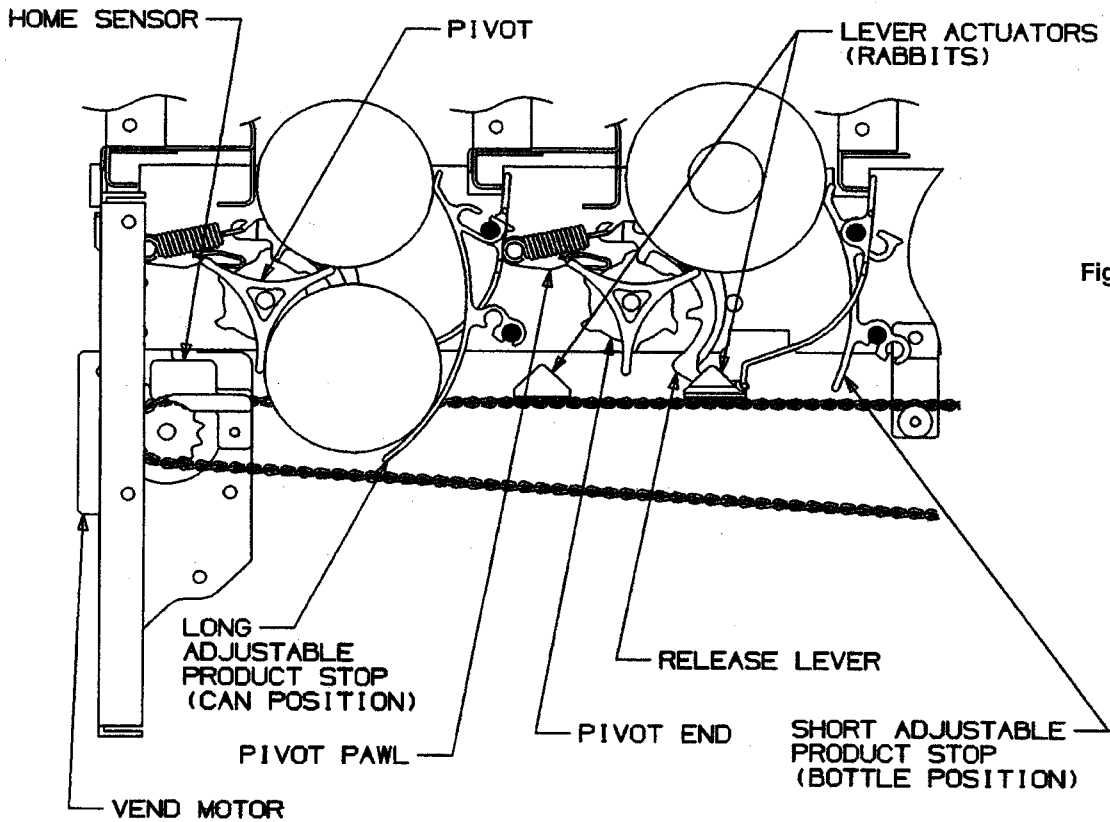

Figure 1-A

INSTALLATION PROCEDURE "B"

Extrusion 79" 815,214,011
72" 815,215,011

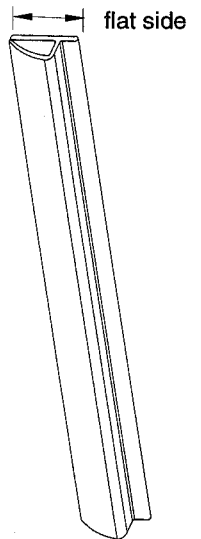

Figure 2

INSTALLATION OF EXTRUSIONS (See Figures 2 & 5)

IMPORTANT NOTE: Make sure that the flat side of the extrusion (See Figure 2) is facing toward the inside of the rear column, this will secure the bottle, keeping it from tilting severely or sliding out of the column.

REAR COLUMN INSTALLATION (2 Extrusions per rear column)

1. Install the 2 extrusions for the rear column one on each side of the rear flanges of the "Center Support" channel. Start by locating one of the flanges, either right or left. These flanges with the extrusions attached will support the bottom of the bottle. Start by pressing the extrusion onto the top of the flange then continue pressing the remainder of the extrusion onto the flange (See Figure 5). Repeat this procedure for the other flange.

FRONT COLUMN INSTALLATION (4 Extrusions per front column)

1. Install extrusions to left and right sides of "Center Support" channel. This procedure is similar to the one for the rear column installation (above in step #1).
2. Install extrusions on the top portion of the "Front Product Retainers", both left and right (Shown in Figure 5). Press the one of the extrusions onto one of the two "Front Product Retainers" for your column. Make sure that the extrusion is aligned at the top edge of the "Front Product Retainer"

NOTE: All extrusions are the same length.

**ANY QUESTIONS??? CONTACT ROYAL VENDORS' CUSTOMER SERVICE DEPARTMENT
CALL TOLL FREE (800) 931-9214**



SERVICE BULLETIN # 00144

201 INDUSTRIAL BOULEVARD • KEARNEYSVILLE, WV 25430
Phone: (304) 728-7056 • Fax: (304) 725-6579 • Toll Free: (800) 931-9214

PAGE: 4 of 7
DATE: 10-24-01
REVISION: 04

SUBJECT: Small Package Vending in Gill Venders

MODELS: Gill Venders

INSTALLATION PROCEDURE "C"

INSTALLATION OF SMALL PACKAGE CLIP ON PRODUCT STOP VENDER SERIAL NUMBER 1379XX-XXXXX AND NEWER ONLY

1. Remove all product from any column desired to be converted. It will also be necessary to remove all product from any joining front or rear column.
2. Lift the black rod retainer clip and remove the bottom product retainer rod (See Figure 5). Position the "Small Package Clip On Product Stop" between the "Fixed" and "Adjustable" product stops as shown in Figure 5, ensure that the top of the "Small Package Clip On Product Stop" (Figure 3) fits securely over the white spacer located on the "top product retainer rod".
3. Replace the bottom product retainer rod as removed in step #2. Make sure that when replacing the rod that it is placed through the proper product stop holes including the bottom hole of the "Small Package Clip On Product Stop".

NOTE: When replacing the product retainer rod it would be a good time to set the "Adjustable Product Stops" to the proper position for the type of package that you intend to vend (as shown in Table #2). The "Fixed Product Stop" however is different than the "Adjustable Product Stop", it has only one position available.

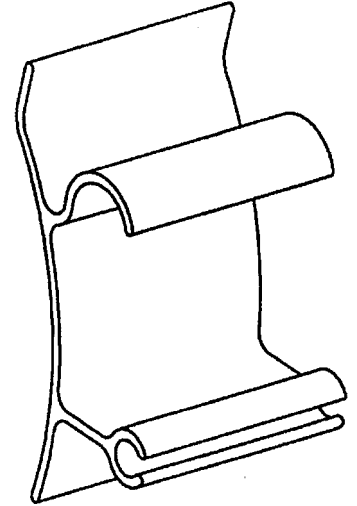

Small Package Clip On Product Stop
Figure 3

INSTALLATION PROCEDURE "D"

INSTALLATION OF SMALL PACKAGE CLIP ON PRODUCT STOP VENDERS PRIOR TO SERIAL NUMBER 1379XX-XXXXX

1. Remove all product from any column desired to be converted. It will also be necessary to remove all product from any joining front or rear column.
2. Lift the black rod retainer clip and remove the "bottom product retainer rod" (See Figure 5).
3. Loosen the Phillips head screw that fastens the rod retainer to the front of the base. Rotate the rod retainer to expose the head of the "top product retainer rod" (See Figure 5).
4. Make note of how this rod and all parts on it are installed, you will need to reinstall them later. Remove the "top product retainer rod". It is advised to slowly remove the rod because it will be necessary to remove all items that the rod supports.
5. Reinstall the top product retainer rod, replacing the auxiliary product stops of any column in which the Small Package Extrusion Kit is being installed, with the white spacers that are included in each kit.
6. Install the "Small Package Clip On Product Stop" between the "Fixed" and "Adjustable" product stops as shown in Figure 5, ensure that the top of the "Small Package Clip On Product Stop" fits securely over the white spacer (installed on the "top product retainer rod" in step #5).
7. Reinstall the bottom product retainer rod as removed in step #4. Make sure that when replacing the rod that it is placed through the proper holes including the bottom hole of the "Small Package Clip On Product Stop".

NOTE: Upon replacing the product retainer rod it would be a good time to set the adjustable product stops to the proper position as shown in Table #2.

ANY QUESTIONS??? CONTACT ROYAL VENDORS' CUSTOMER SERVICE DEPARTMENT
CALL TOLL FREE (800) 931-9214



SERVICE BULLETIN # 00144

201 INDUSTRIAL BOULEVARD • KEARNEYSVILLE, WV 25430
Phone: (304) 728-7056 • Fax: (304) 725-6579 • Toll Free: (800) 931-9214

PAGE: 5 of 7
DATE: 10-24-01
REVISION: 04

SUBJECT: Small Package Vending in GIII Venders

MODELS: GIII Venders

INSTALLATION PROCEDURE "E"

INSTALLATION OF ANTI-BRIDGING PLATE ASSEMBLY (See Figure 4)

1. Unload column to be retrofitted.
2. Peel the backing from the 3 pieces of the "two-sided" tape on the rear of the Anti-Bridging Plate".
3. Place the "Anti-Bridging Plate" on the column wall against the center channel (divider between the front and rear columns). Make sure that the edge of the "Anti-Bridging Plate" with 1/2" of metal exposed is aligned against the center channel as shown in Figure 4. Locate the bottom edge of the "Anti-Bridging Plate" just beneath the top edge adjustable product stop as shown in Figure 4.

NOTE: There is only one "Anti-Bridging Plate" per kit and it is to be installed on the right column wall as shown below in Figure 4

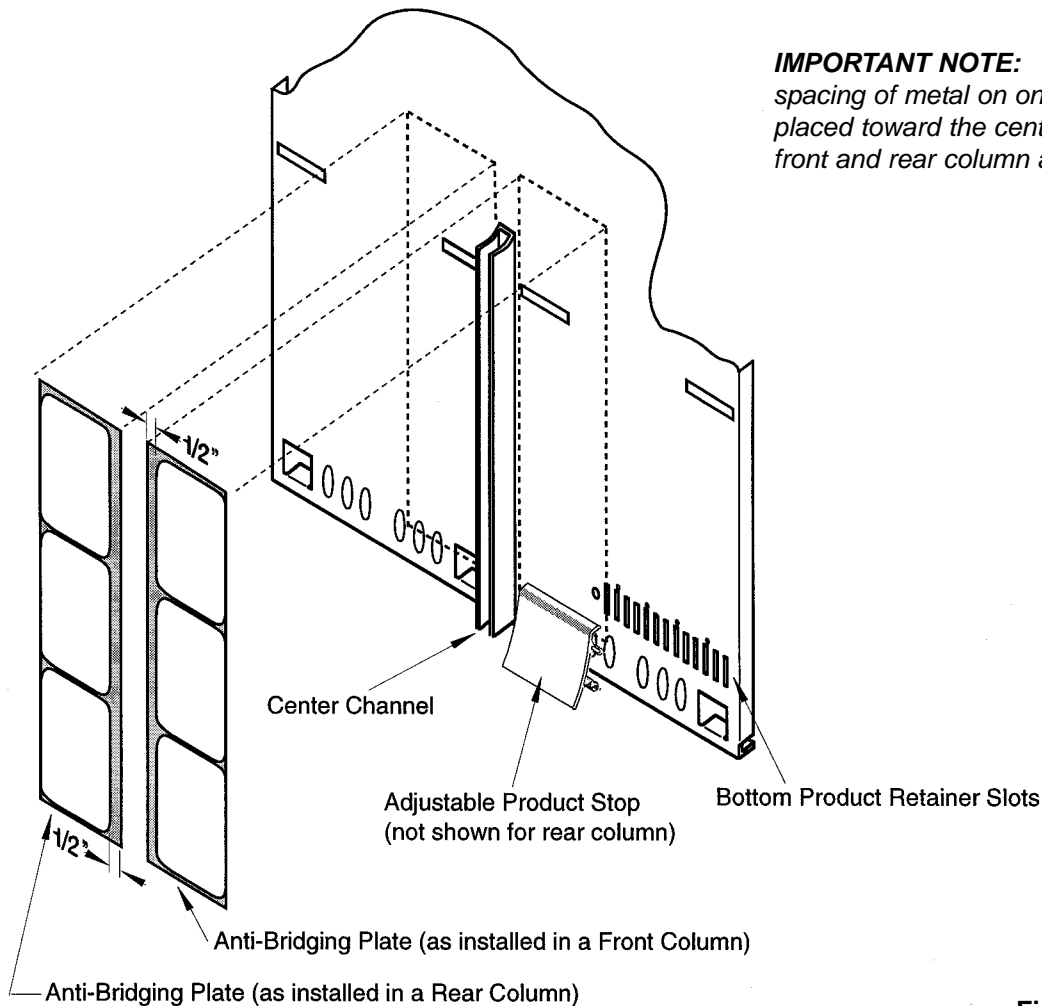

Figure 4

**ANY QUESTIONS??? CONTACT ROYAL VENDORS' CUSTOMER SERVICE DEPARTMENT
CALL TOLL FREE (800) 931-9214**



SERVICE BULLETIN # 00144

201 INDUSTRIAL BOULEVARD • KEARNEYSVILLE, WV 25430

Phone: (304) 728-7056 • Fax: (304) 725-6579 • Toll Free: (800) 931-9214

PAGE: 6 of 7
DATE: 10-24-01
REVISION: 04

SUBJECT: Small Package Vending in GIII Venders

MODELS: GIII Venders

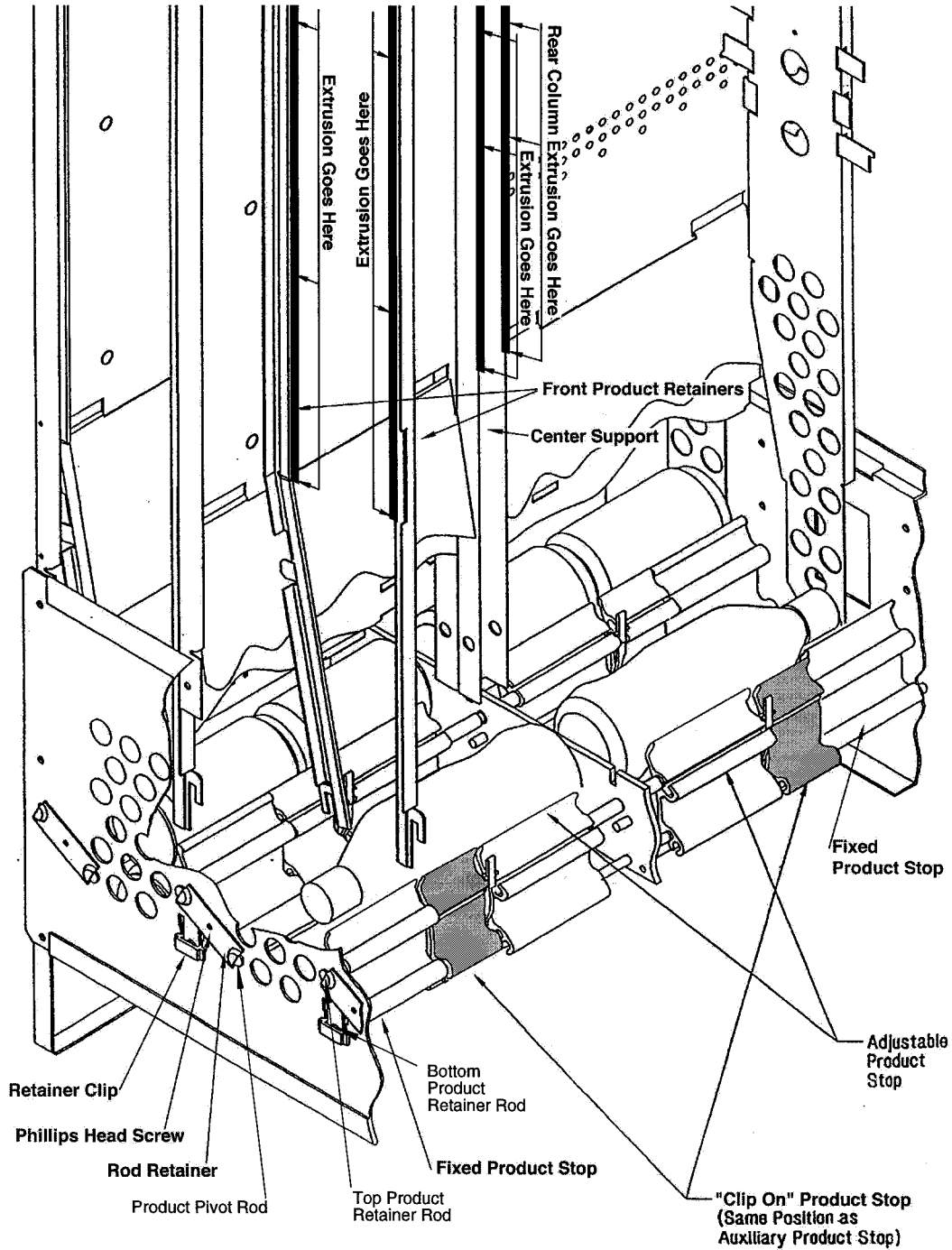

Figure 5

**ANY QUESTIONS??? CONTACT ROYAL VENDORS' CUSTOMER SERVICE DEPARTMENT
CALL TOLL FREE (800) 931-9214**



SERVICE BULLETIN # 00144

201 INDUSTRIAL BOULEVARD • KEARNEYSVILLE, WV 25430
Phone: (304) 728-7056 • Fax: (304) 725-6579 • Toll Free: (800) 931-9214

PAGE: 7 of 7
DATE: 10-24-01
REVISION: 04

SUBJECT: Small Package Vending in GIII Venders

MODELS: GIII Venders

INSTALLATION PROCEDURE "F"

INSTALLATION OF EXTRUSIONS (See Figures 2 & 4)

IMPORTANT NOTE: Make sure that the flat side of the extrusion (See Figure 2) is facing toward the inside of the rear column, this will secure the bottle, keeping it from tilting severely or sliding out of the column.

REAR COLUMN INSTALLATION (2 Extrusions per rear column)

1. Install the 2 extrusions for the rear column one on each side of the rear flanges of the "Center Support" channel. Start by locating one of the flanges, either right or left. These flanges with the extrusions attached will support the bottom of the bottle. Start by pressing the extrusion onto the top of the flange then continue pressing the remainder of the extrusion onto the flange (See Figure 5). Repeat this procedure for the other flange.

FRONT COLUMN INSTALLATION (2 Extrusions & 2 Extensions per front column)

1. Install extrusions to left and right sides of "Center Support" channel. This procedure is similar to the one for the rear column installation (above in step #1).
2. Install the Front Retainer Extensions to the top portion of the "Front Product Retainers", both left and right side. (See Figures 6 & 7 for correct positioning).

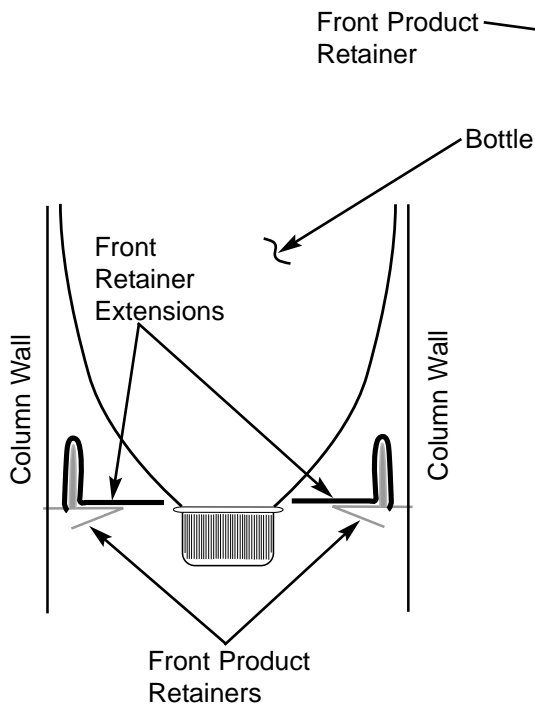

Figure 6

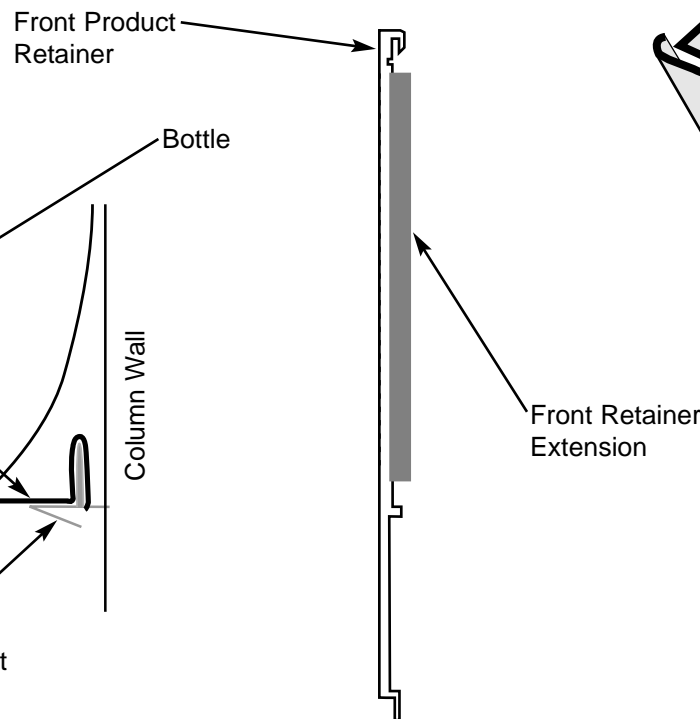
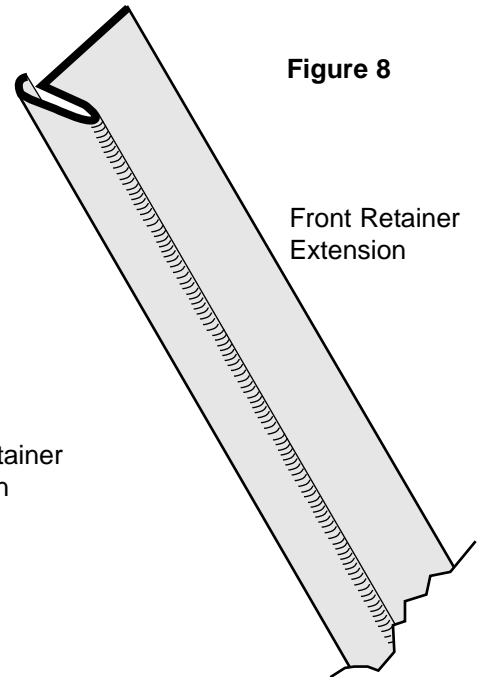

Figure 7



1. Front Retainer Extension 79" (8152561)
2. Front Retainer Extension 72" (815255)

ANY QUESTIONS??? CONTACT ROYAL VENDORS' CUSTOMER SERVICE DEPARTMENT
CALL TOLL FREE (800) 931-9214