

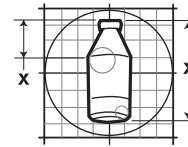

013 Package Vending Specification

426 Industrial Boulevard • Kearneysville WV 25430-2776 • USA
 Telephone: +1 304 728 7056 • technicalinquiry@royalvendors.com
 Toll-free in North America: 1 800 931 9214 • Fax: +1 304 725 4016
 Canada: +1 905 738 5777 • Mexico: +52 55 5203 6887
 Europe: +49 2158 95 1000 • Australia: +61 2 9890 5433



Page: 1 of 7
 Date: 10 Mar 09
 Revision: 06

SUBJECT: 240 mL / 250 mL Can		
MODELS: GIII, Merlin RB, MIV, EZ, Electro-Mechanical, Merlin 2000, Merlin III		
Kit Number	Kit Description	Page
232051	72" 250 mL Package Kit, Front Column, GIII	1
232052	72" 250 mL Package Kit, Rear Column, GIII	1
231051	79" 250 mL Package Kit, Front Column, GIII	1
231052	79" 250 mL Package Kit, Rear Column, GIII	1
256017	240 / 250 mL Can Kit (79" Front), MIV	4
256018	240 / 250 mL Can Kit (79" Rear), MIV	4
257017	240 / 250 mL Can Kit (72" Front), MIV	4
257018	240 / 250 mL Can Kit (72" Rear), MIV	4
324740	240 / 250 mL Can Kit (Columns 1-5), EZ	5
324750	240 / 250 mL Can Kit (Column 6), EZ	5



HEIGHT
5.22 in. / 13.3 cm

DIAMETER
2.08 in. / 5.3 cm

WEIGHT
0.58 lbs. / 0.26 kg

PACKAGE TYPE
Aluminium can

COUNTRY OF ORIGIN
Worldwide distribution



The following areas of this vender contain voltage which can cause serious injury or even death: the main power cord, supplying 115-230 VAC to the evaporator, EMI filter, and refrigeration system; the power line from the EMI filter to the ballast and transformer; and the ballast, which can produce upwards of 600 volts. Remove all power from the vender before working in any of these areas.

GIII Instructions

INSTALLING THE 250mL CAN STOP

1. Remove the existing product from the column to be converted.
2. Remove the product stops currently in use for each column receiving a kit.
3. The setup for both front and rear columns is shown in figures 1, 2, and 3.
Add spacers and stops in the following order (front to rear):

- A. 1.00" (25 mm) spacer
- B. 2.90" (74 mm) wide standard product stop
- C. 0.720" (18 mm) spacer
- D. Anti-tilt plate
- E. 4.951" (126 mm) wide 250mL can stop
- F. 1.250" (32 mm) spacer
- G. 1.250" (32 mm) spacer
- H. 4.951" wide (126 mm) 250mL can stop
- I. Anti-tilt plate
- J. 0.720" (18 mm) spacer
- K. 2.90" (74 mm) wide standard product stop
- L. 0.50" (13 mm) spacer

3. While adjusting the product stops, remove the black anti-rotation pawl (dog) from each column that receives a kit.

INSTALLING THE PLASTIC EXTRUSION (Right Side)

The rear extrusion is smaller than the front extrusion in order to allow sufficient clearance to install the part. The front extrusion is sized to run the entire height of the column. Do not load product past the top of the rear extrusion.

1. The clip that runs along the outside of the extrusion is designed to engage either flange of the center-divider (channel). When fully engaged, it will snap past the hem at the leading edge of the channel's flange, providing a secure connection to the channel.
2. Once clipped into place, the extrusions should be slid downward so they rest on top of the new 250mL can stop(s).
3. Extrusion kits can be installed singularly or in pairs within the same column bay.
4. Adjust the retainers, and the vender is ready.

Figure 1

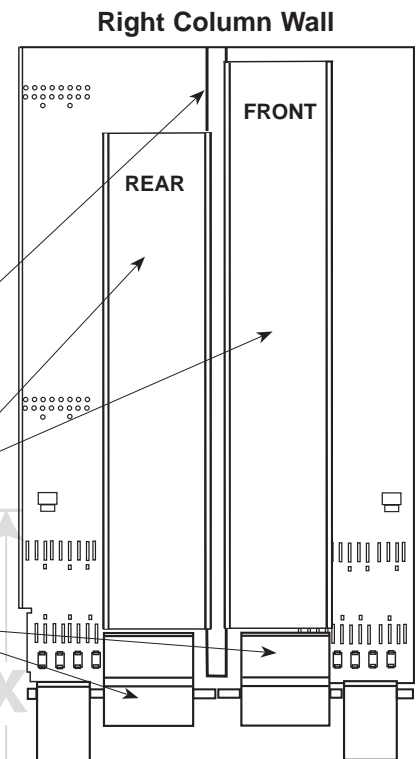

**ANY QUESTIONS? CONTACT ROYAL VENDORS' CUSTOMER SERVICE DEPARTMENT
 IN NORTH AMERICA, CALL TOLL FREE 1 800 931 9214**



013 Package Vending Specification

426 Industrial Boulevard • Kearneysville WV 25430-2776 • USA
Telephone: +1 304 728 7056 • technicalinquiry@royalvendors.com
Toll-free in North America: 1 800 931 9214 • Fax: +1 304 725 4016
Canada: +1 905 738 5777 • Mexico: +52 55 5203 6887
Europe: +49 2158 95 1000 • Australia: +61 2 9890 5433

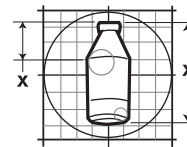

PRODUCT NAME: 240 mL / 250 mL Can

ADJUSTING PRODUCT RETAINERS

The procedure for adjusting the product retainers is different depending upon the serial number of the vender:

GIII STACK (serial numbers beginning with 1503 and before):

1. In rear columns, use the standard rear retainer (backspacer). With the shim kit installed, slide the retainer forward as far as it will go, and engage the spring fingers on the right side into the right partition wall at position 9. Next, swing the left side of the retainer assembly forward so that the fingers on its left side engage the next pair of holes in the left column wall at position 10 (one position closer to the front of the vender). It is very important that the retainer be angled forward on the left side to prevent cans from catching the lip of the plastic extrusion as they approach the pivot.
2. In front columns, place the retainer in position 10.

GIII STACK (serial numbers beginning with 1504 and after):

1. The column walls are slotted to accept front retainers in both the front and rear columns; therefore, additional front retainers may be used as retainers for the rear columns. When a rear column is fitted with a 250mL shim kit, place a front retainer in position 10. The rear retainer (backspacer) can be pushed all the way to the back of the vender where it is out of the way.
2. In front columns, place the retainer in position 10.

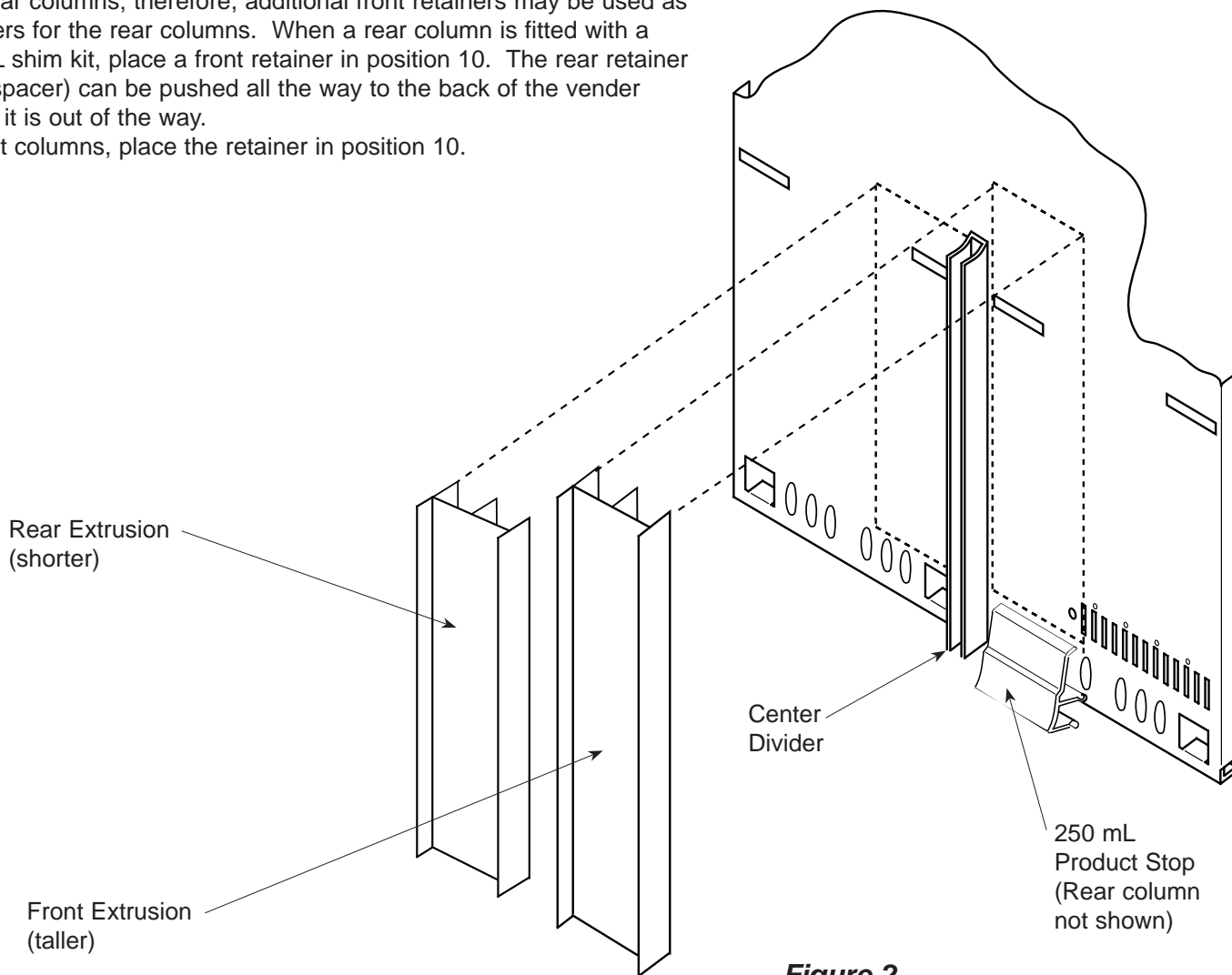

Figure 2

**ANY QUESTIONS? CONTACT ROYAL VENDORS' CUSTOMER SERVICE DEPARTMENT
IN NORTH AMERICA, CALL TOLL FREE 1 800 931 9214**



013 Package Vending Specification

426 Industrial Boulevard • Kearneysville WV 25430-2776 • USA
 Telephone: +1 304 728 7056 • technicalinquiry@royalvendors.com
 Toll-free in North America: 1 800 931 9214 • Fax: +1 304 725 4016
 Canada: +1 905 738 5777 • Mexico: +52 55 5203 6887
 Europe: +49 2158 95 1000 • Australia: +61 2 9890 5433

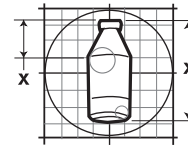

Page: 3 of 7
Date: 10 Mar 09
Revision: 06

PRODUCT NAME: 240 mL / 250 mL Can

Figure 3

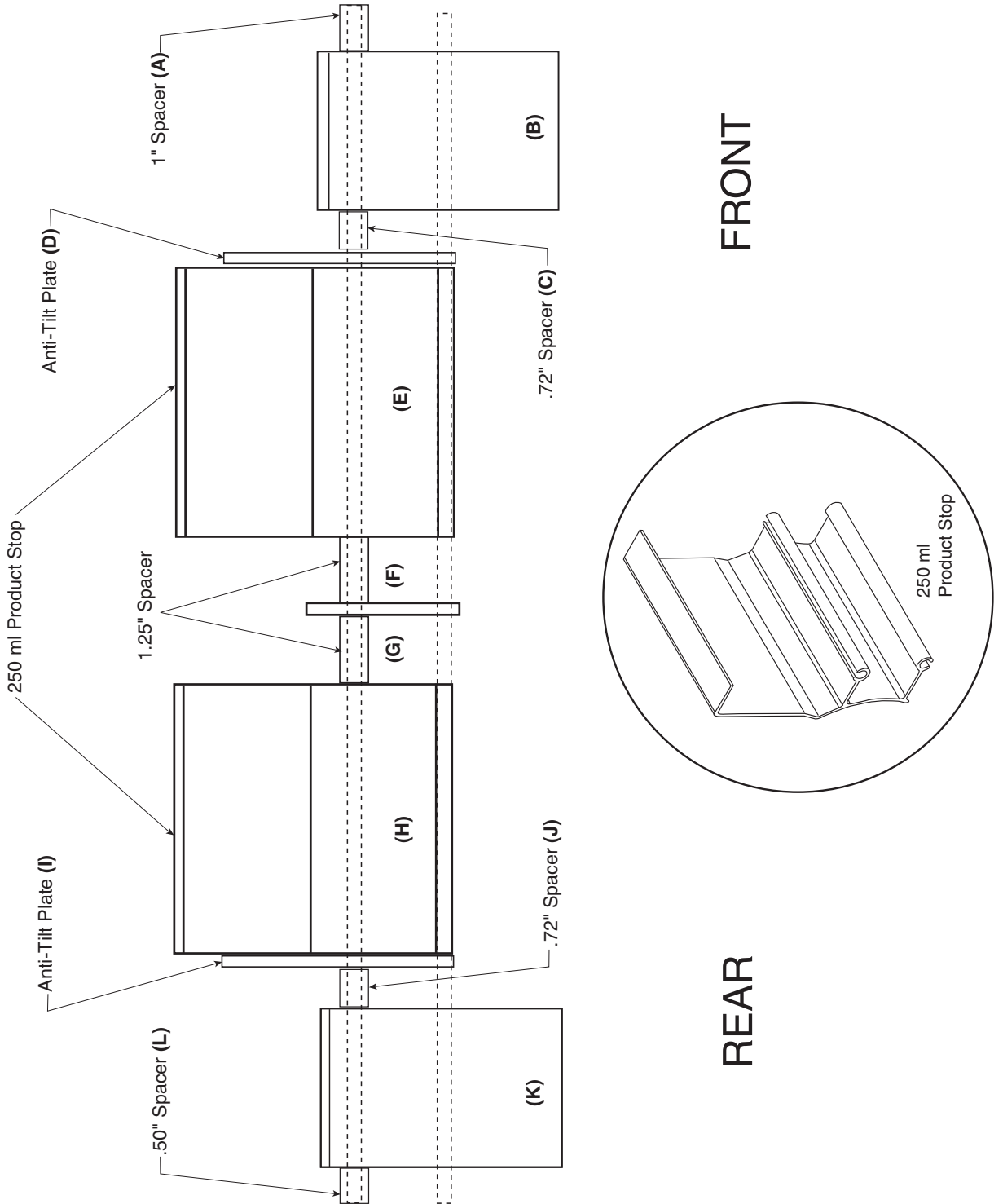

**ANY QUESTIONS? CONTACT ROYAL VENDORS' CUSTOMER SERVICE DEPARTMENT
 IN NORTH AMERICA, CALL TOLL FREE 1 800 931 9214**



013 Package Vending Specification

426 Industrial Boulevard • Kearneysville WV 25430-2776 • USA
Telephone: +1 304 728 7056 • technicalinquiry@royalvendors.com
Toll-free in North America: 1 800 931 9214 • Fax: +1 304 725 4016
Canada: +1 905 738 5777 • Mexico: +52 55 5203 6887
Europe: +49 2158 95 1000 • Australia: +61 2 9890 5433

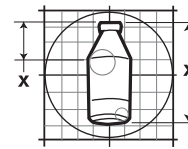

PRODUCT NAME: 240 mL / 250 mL Can

Merlin RB Instructions

Set right product retainer to position 15. Set selection depth to 3. Load cans three-deep. The top of the can may face toward the front or toward the rear of the vender, as long as all cans are loaded in the same direction. No kits or additional setup required. **Capacity:** 96 cans per column.

Merlin IV Instructions (kits can be installed singularly or in pairs within the same column bay)

1. Remove the existing product from the column to be converted. **Note:** If converting from 1 Liter vender, it will be necessary to install a can filler (part number 256107 front column / 256108 rear column), then proceed with directions.
2. Install the 240/250 mL can filler on left-hand side of column. (See Figure 4.)
3. Install white plastic extrusion on left hand side of the column wall. Install the small extrusion on top of the long extrusion to ensure full capacity.

When installing the white extrusion:

- a. The clip that runs along the outside of the extrusion is designed to engage either flange of the center-divider (channel). When fully engaged, it will snap past the hem at the leading edge of the channel's flange, providing a secure connection to the channel.
 - b. Slide the white extrusion down until angle is flush with baffle
4. Install a black extrusion on the front right side retainer. See figure 5.
 5. **Serial number 200422XX00001 and after:** Adjust the front retainers to position 9. Set the rear retainer (back spacer) to 10 right / 9 left.
Prior to serial number 200422XX00001: Adjust the front retainers to position 10. Set the rear retainer (backspacer) to 11 right / 10 left.

LEFT COLUMN WALL

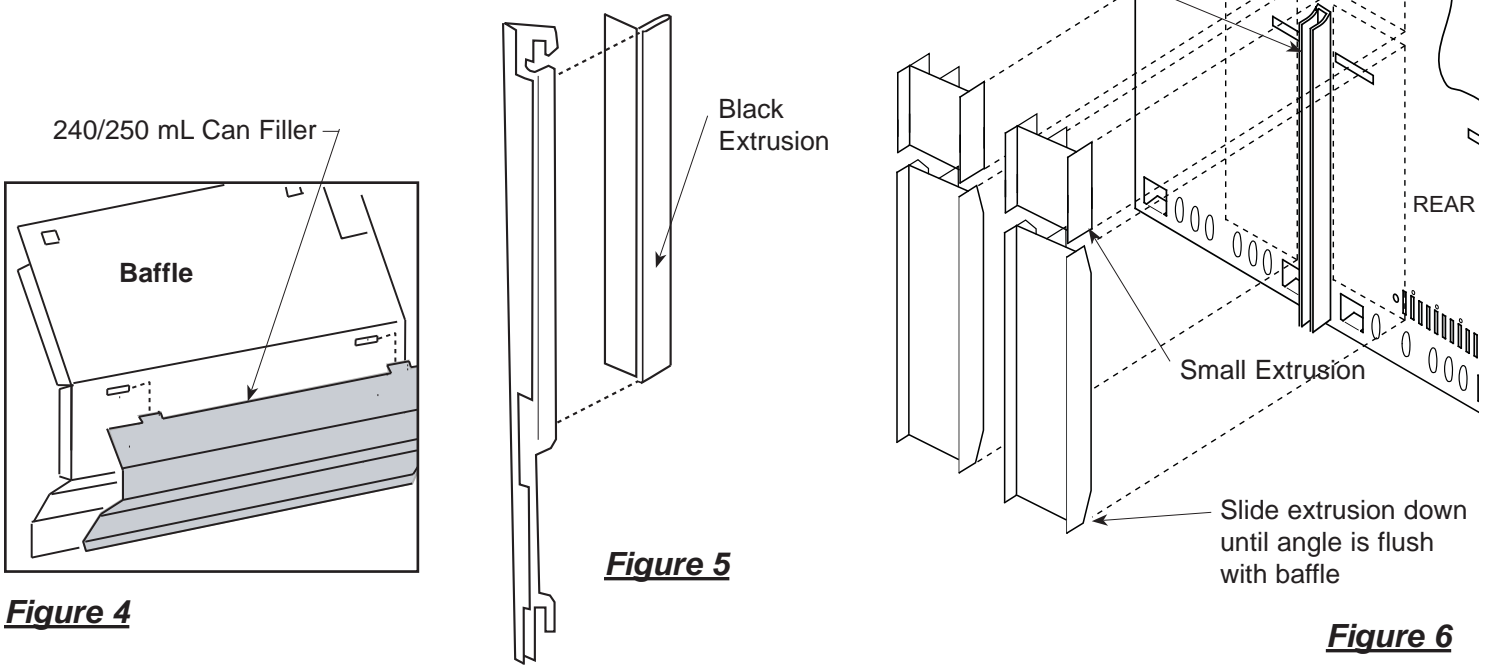

**ANY QUESTIONS? CONTACT ROYAL VENDORS' CUSTOMER SERVICE DEPARTMENT
IN NORTH AMERICA, CALL TOLL FREE 1 800 931 9214**



013 Package Vending Specification

426 Industrial Boulevard • Kearneysville WV 25430-2776 • USA
Telephone: +1 304 728 7056 • technicalinquiry@royalvenders.com
Toll-free in North America: 1 800 931 9214 • Fax: +1 304 725 4016
Canada: +1 905 738 5777 • Mexico: +52 55 5203 6887
Europe: +49 2158 95 1000 • Australia: +61 2 9890 5433

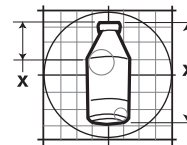

PRODUCT NAME: 240 mL / 250 mL Can

EZ Vender Instructions

1. Remove existing product from column that you intend to convert over to 240 mL / 250 mL cans.
2. Remove the wiring cover plate from the front of the vend mechanism assembly (stack).
3. Pull out the product stop holding rod.
4. Remove the existing product stop, and replace it with the 240/250 mL product stop assembly from the kit. (See Figures 7 and 8.)
5. Reinstall the product stop rod.
6. Replace and secure the wiring cover plate.
7. Install the 240/250 mL retainer (included in the kit) on one of the 240/250 mL fillers from the kit. Secure it with the two supplied screws. Only tighten the screws about three-quarters of the way in. (See Figure 9.)
8. Install the 240/250 mL fillers in the vender. Install the filler **without** the retainer attached in position 48 on the left column wall. Install the filler **with** the retainer attached in position 18 on the left column wall. (See Figure 10.)
9. Install the anti-friction sheets in the positions shown in Figure 11.
10. Place the right column retainer in position 17 on the right column wall.
11. Enter the vender's programming, and set "SdEP" to "3" for all selections vending the 240 mL / 250 mL can.
12. Load cans three-deep, with all cans facing one direction. Once the cans have been loaded, place the retainer in the vending position, as shown in Figure 12.

Figure 7.

240/250 mL product stop assembly (goes in place of existing product stop on EZ Vender)

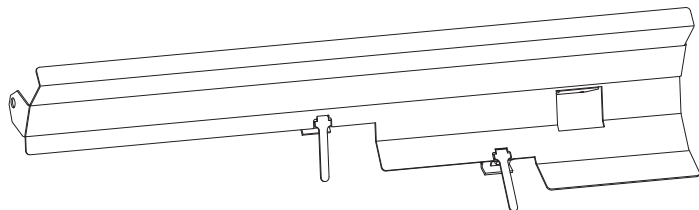

Figure 8.

240/250 mL product stop assembly installed

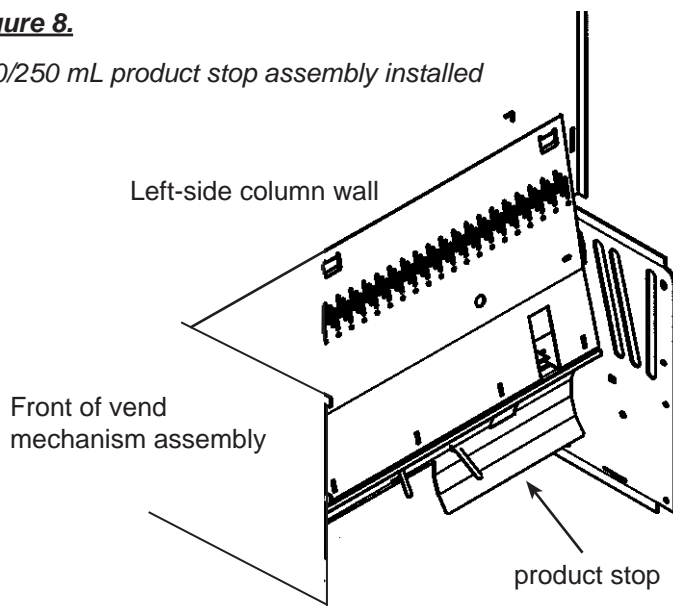
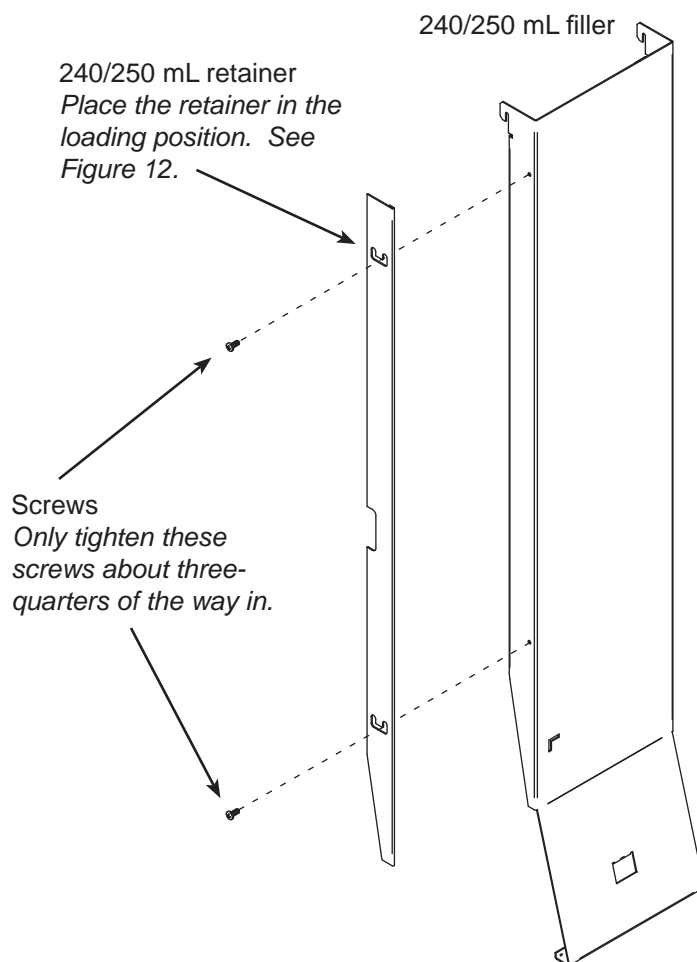

Figure 9.

Installation of the 240/250 mL retainer.



**ANY QUESTIONS? CONTACT ROYAL VENDORS' CUSTOMER SERVICE DEPARTMENT
IN NORTH AMERICA, CALL TOLL FREE 1 800 931 9214**



013 Package Vending Specification

426 Industrial Boulevard • Kearneysville WV 25430-2776 • USA
 Telephone: +1 304 728 7056 • technicalinquiry@royalvendors.com
 Toll-free in North America: 1 800 931 9214 • Fax: +1 304 725 4016
 Canada: +1 905 738 5777 • Mexico: +52 55 5203 6887
 Europe: +49 2158 95 1000 • Australia: +61 2 9890 5433

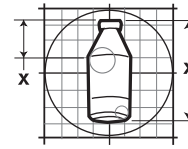

Page: 6 of 7
Date: 10 Mar 09
Revision: 06

PRODUCT NAME: 240 mL / 250 mL Can

Figure 10.

Installing the fillers

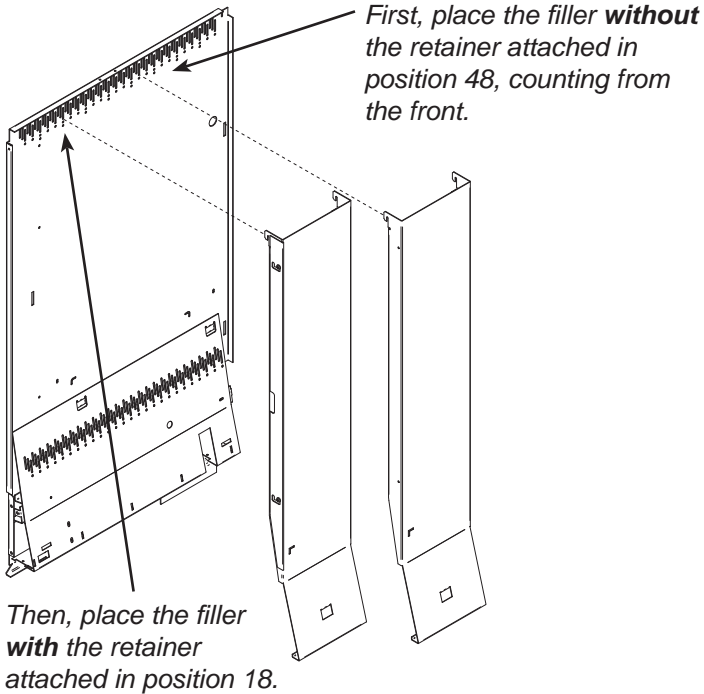

Figure 11.

Installing the anti-friction sheets

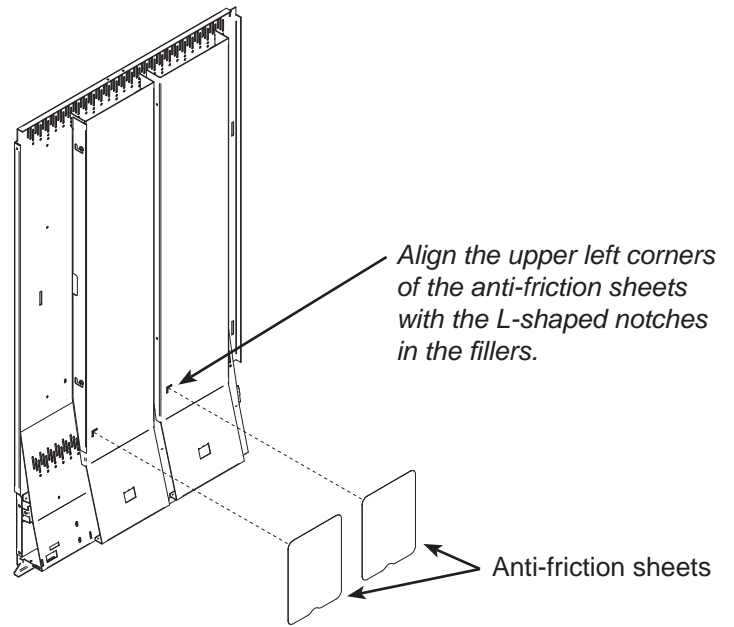
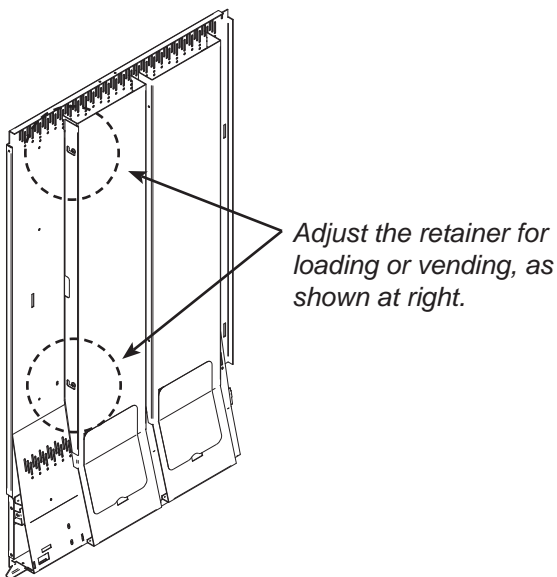

Figure 12.

Retainer positions



Loading position

When loading the vender, place the retainer in the position shown here.

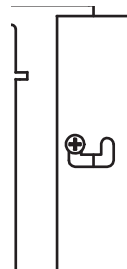

Vending position

After the vender has been loaded with product, place the retainer so that the screw is in the slot to the left.

**ANY QUESTIONS? CONTACT ROYAL VENDORS' CUSTOMER SERVICE DEPARTMENT
 IN NORTH AMERICA, CALL TOLL FREE 1 800 931 9214**



013 Package Vending Specification

426 Industrial Boulevard • Kearneysville WV 25430-2776 • USA
 Telephone: +1 304 728 7056 • technicalinquiry@royalvendors.com
 Toll-free in North America: 1 800 931 9214 • Fax: +1 304 725 4016
 Canada: +1 905 738 5777 • Mexico: +52 55 5203 6887
 Europe: +49 2158 95 1000 • Australia: +61 2 9890 5433

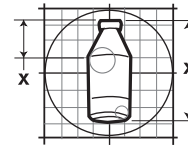

Page: 7 of 7
Date: 10 Mar 09
Revision: 06

PRODUCT NAME: 240 mL / 250 mL Can

Electro-Mechanical, Merlin 2000, Merlin III

NOTES: 1. Double-depth only, for narrow column.
 2. Can shim to be placed on right side of each narrow column.

	2 Deep	3 Deep	3 Deep+
Rear Spacer Setting (Counting from the rear)	4	10	12
Can Shim p/n	010123	058103	201117
Can Spacer p/n	010117	058102	201124
Shim Rod p/n	803007	803009	803033
Spring p/n	914006	914006	914006

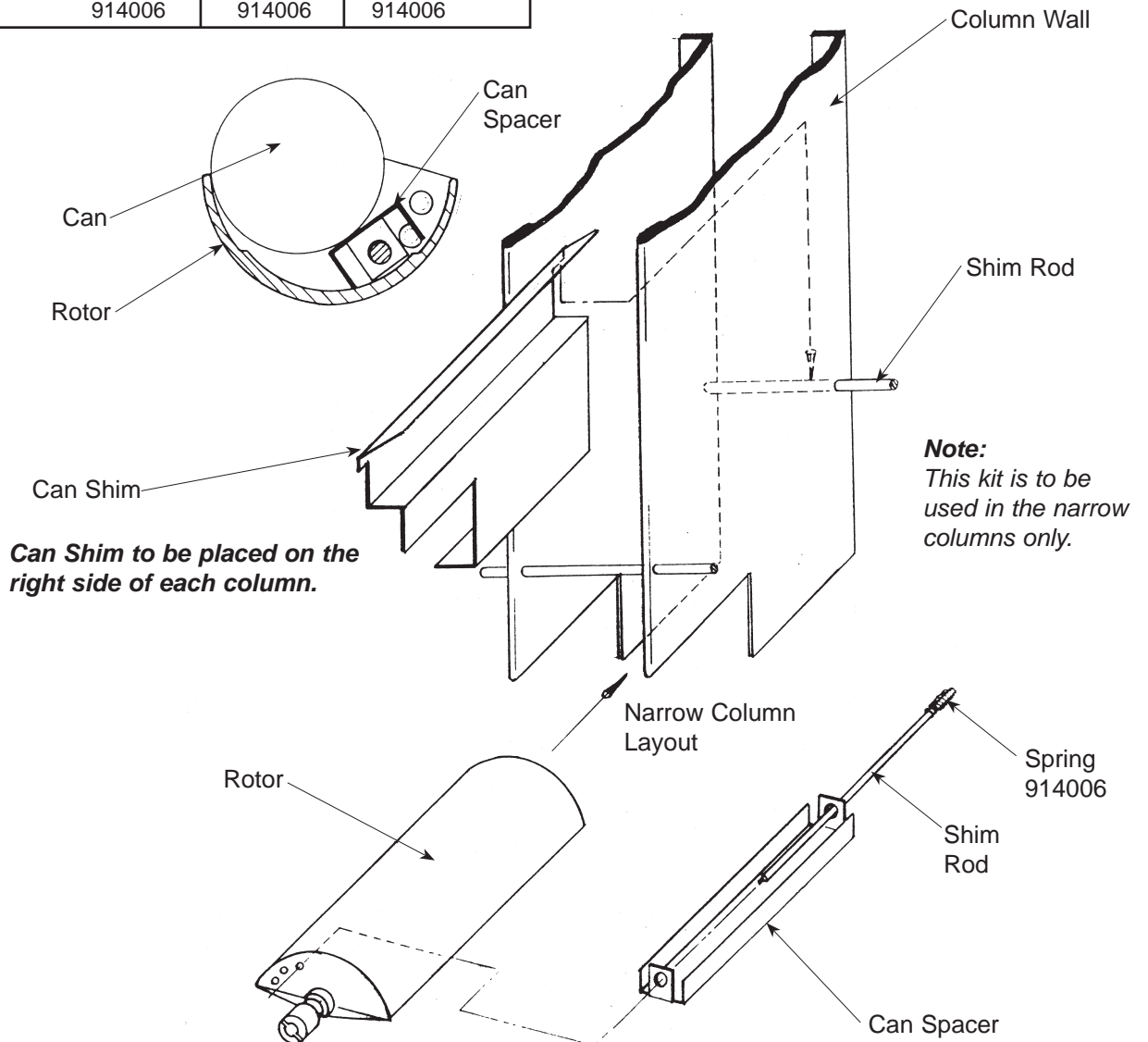

**ANY QUESTIONS? CONTACT ROYAL VENDORS' CUSTOMER SERVICE DEPARTMENT
 IN NORTH AMERICA, CALL TOLL FREE 1 800 931 9214**