

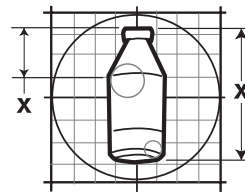

059 Package Vending Specification

201 Industrial Boulevard • Kearneysville, WV 25430
 Phone: (304) 728-7056 • Fax: (304) 725-6579



PAGE: 1 of 1
DATE: 5-22-03
REVISION: 03

PRODUCT NAME: 20 oz. Shamrock Farms
BOTTLER / COMPANY: Shamrock Farms Dairy
VOLUME: 20 oz. / 591 mL
PACKAGE TYPE: PET
HEIGHT: 8.3 in. / 21.1 cm
DIAMETER: 2.6 in. / 6.6 cm
WEIGHT: 1.46 lbs. / 0.66 kg
COUNTRY OF ORIGIN: USA

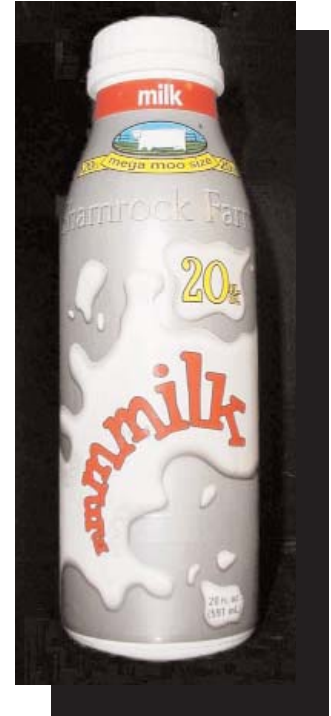

APPROVED VENDERS				
VENDER	RETAINERS		72" CAPACITY	
	Front	Rear	Front	Rear
Milk	7	see below	26	26

KITS / PARTS: *Front columns:* None required. *Rear columns:* p/n 332103 Shamrock 20 oz. kit - rear.

SPECIAL INSTRUCTIONS: In rear columns, install left and right product retainers, set in position 14. Set back spacers in position 2. Load bottles with caps to the front in all columns.

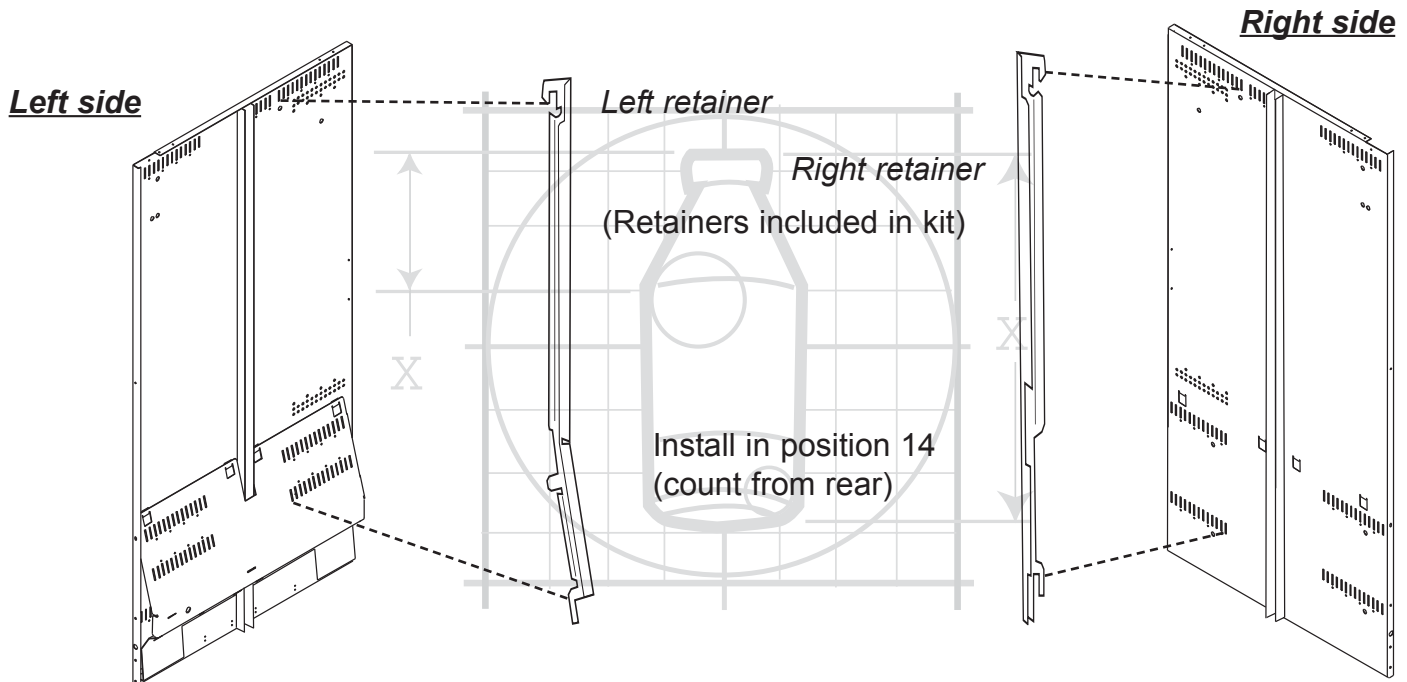

ANY QUESTIONS??? CONTACT ROYAL VENDORS' CUSTOMER SERVICE DEPARTMENT
CALL TOLL FREE (800) 931-9214