

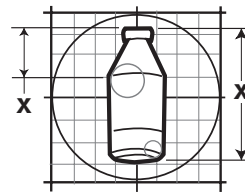

# 049 Package Vending Specification

201 Industrial Boulevard • Kearneysville, WV 25430  
 Phone: (304) 728-7056 • Fax: (304) 725-6579



|               |
|---------------|
| PAGE: 1 of 2  |
| DATE: 4-29-02 |
| REVISION: 00  |

**PRODUCT NAME:** Tropicana Smoothies  
**BOTTLER / COMPANY:** Tropicana Products, Inc.  
**VOLUME:** 11.5 oz. / 340 mL  
**PACKAGE TYPE:** Square plastic bottle  
**HEIGHT:** 6.69 in. / 17.0 cm  
**WEIGHT:** 0.84 lbs. / 0.38 kg  
**DIAMETER:** 2.26 in. / 5.7 cm side; 2.65 in. / 6.7 cm diagonal  
**COUNTRY OF ORIGIN:** USA



## APPROVED VENDERS

| VENDER      | RETAINERS |      | 72" CAPACITY |      |
|-------------|-----------|------|--------------|------|
|             | Front     | Rear | Front        | Rear |
| Milk Vender | N/A       | 7    | N/A          | 20   |

**Kits / Parts:** 332115 Tropicana Smoothies Kit

## KIT INSTALLATION INSTRUCTIONS:

**Note:** This package can not be vended in front columns.

1. Remove existing product from column that you intend to convert over to Tropicana Smoothies bottles.
2. Mount small package filler on left hand side of column. See Figure 1.
3. Install white plastic extrusion on right hand side of the rear column wall. See Figure 2.
4. **When installing the white extrusion:**
  - a. The clip that runs along the outside of the extrusion is designed to engage either flange of the center-divider (channel). When fully engaged, it will snap past the hem at the leading edge of the channel's flange, providing a secure connection to the channel.
  - b. The top of the extrusion should be 5" down from the top of the inside of the cabinet.
5. Set the rear retainer (backspacer) to position 7.
6. Load bottles with caps to the rear.

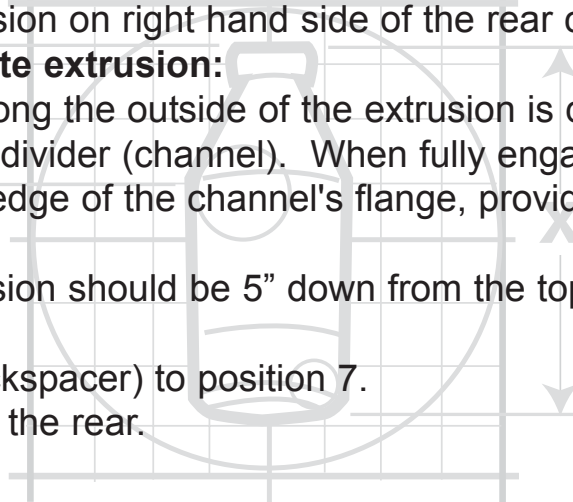

**ANY QUESTIONS???** CONTACT ROYAL VENDORS' CUSTOMER SERVICE DEPARTMENT  
**CALL TOLL FREE (800) 931-9214**



# 049 Package Vending Specification

201 Industrial Boulevard • Kearneysville, WV 25430  
Phone: (304) 728-7056 • Fax: (304) 725-6579

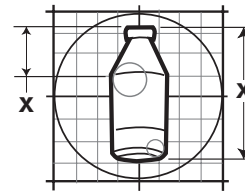

|               |
|---------------|
| PAGE: 2 of 2  |
| DATE: 4-29-02 |
| REVISION: 00  |

**PRODUCT NAME:** Tropicana Smoothies

**Figure 1**

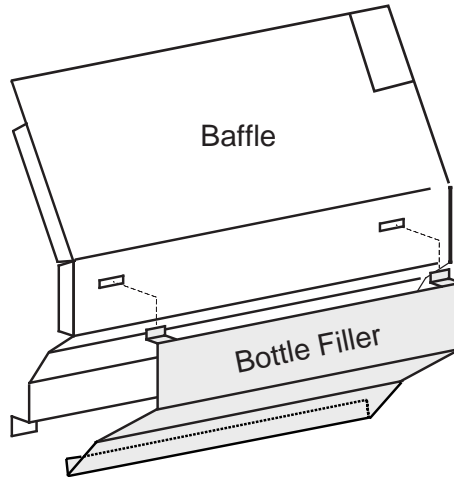

**Figure 2**

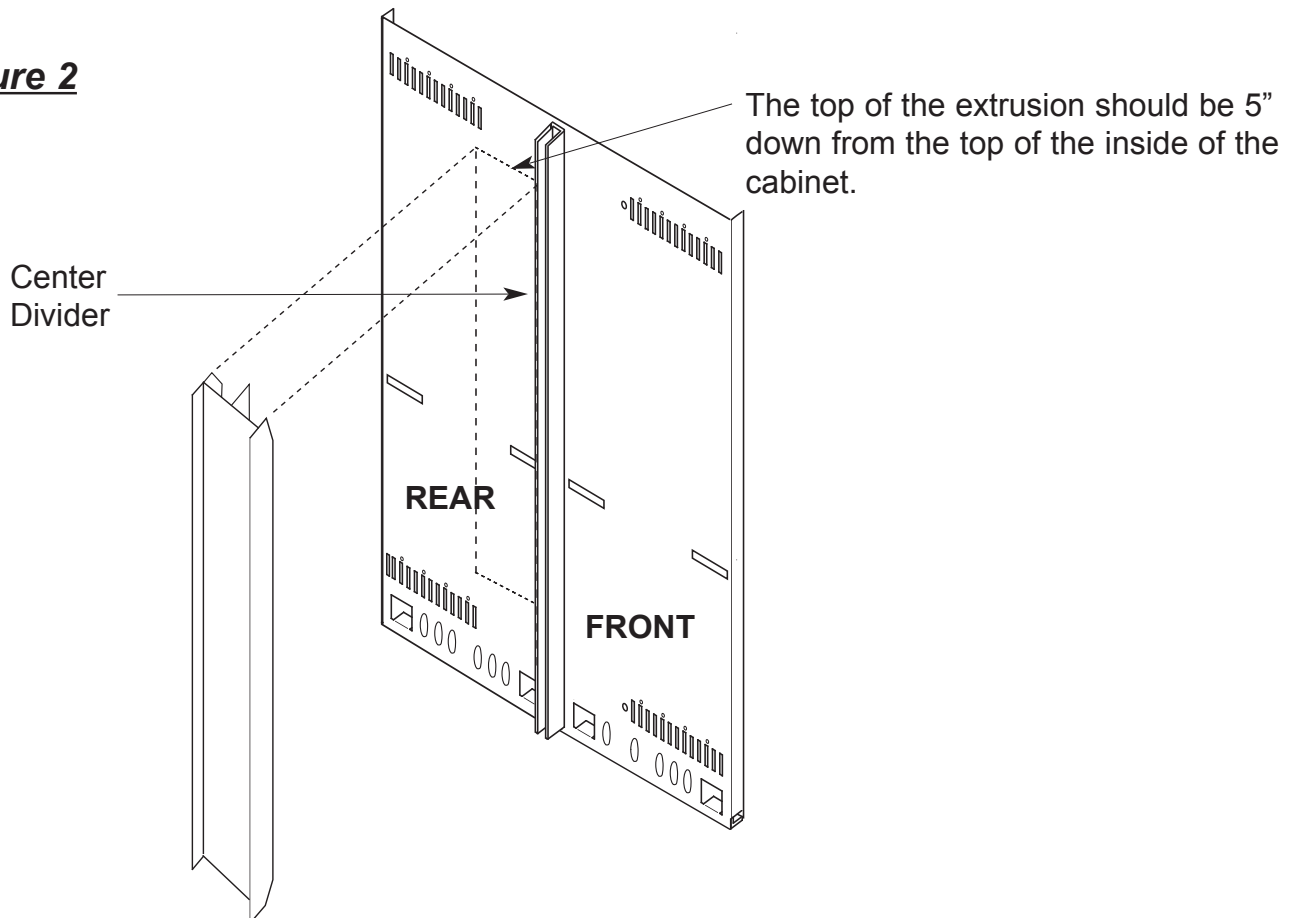

**ANY QUESTIONS??? CONTACT ROYAL VENDORS' CUSTOMER SERVICE DEPARTMENT  
CALL TOLL FREE (800) 931-9214**