

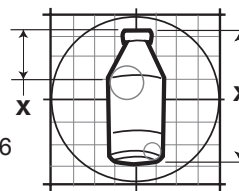

012

Package Vending Specification

426 Industrial Boulevard • Kearneysville WV 25430-2776
 Phone: (304) 728-7056 • Fax: (304) 725-6579



PAGE: 1 of 4
DATE: 12-3-03
REVISION: 01

PRODUCT NAME: Powerade 12 oz.
BOTTLER / COMPANY: Coca-Cola
VOLUME: 12 oz. / 355 mL
PACKAGE TYPE: PET
HEIGHT: 5.94 in. / 15.1 cm
DIAMETER: 2.62 in. / 6.7 cm
WEIGHT: 0.92 lbs. / 0.42 kg
COUNTRY OF ORIGIN: USA



APPROVED VENDERS

VENDER	RETAINERS		79" CAPACITY		KITS / PARTS / INSTRUCTIONS
	F	R	F	R	
GIII (1463 & after)	12	8	32	32	See Instructions Section A
GIII (prior to 1463)	11	8	32	32	See Instructions Section B
GII	Rear only	Front	N/A	31	See Instructions Section C
2 Deep	1		N/36, W/72 Double Deep		Wide columns load butt to butt Caps to rear in narrow column See Instructions Section H
3 Deep (prior to 1352)	9		N/36, W/72 Double Deep		Wide columns load butt to butt Caps to rear in narrow column See Instructions Section D
3 Deep + (1352 and after)	9		N/36, W/72 Double Deep		Wide columns load butt to butt Caps to rear in narrow column See Instructions Section E
3 Deep 16 oz (prior to 1352)	N/9 W/19		N/38, W/68 Wide Single Deep Narrow Double Deep		Narrow: Right side-one 058135 first, then one 201101. Also use one rod 803009 and spring 914006 in center rotor hole. Wide: Use two 058105 on both sides. Then one 058180 on the right and one 058190 on the left. Replace the top two screws in the vend motor (8/32 x 1/4") with two 901038 (8/32 x 1/2) if sold out paddles are not present. Load Caps to the rear. See Instructions Section F

**ANY QUESTIONS??? CONTACT ROYAL VENDORS' CUSTOMER SERVICE DEPARTMENT
 CALL TOLL FREE (800) 931-9214**



012

Package Vending Specification

426 Industrial Boulevard • Kearneysville WV 25430-2776
 Phone: (304) 728-7056 • Fax: (304) 725-6579

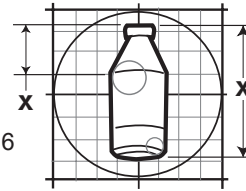

PAGE: 2 of 4

DATE: 12-3-03

REVISION: 01

PRODUCT NAME: Powerade 12 oz.

VENDER	RETAINERS	79" CAPACITY	KITS / PARTS / INSTRUCTIONS
3 Deep +16oz (1352 and after)	N/9 W/19	N/38, W/68 Wide single deep, Narrow double deep	Narrow: Right side-one 201129 first, then one 201106. Also use one rod 803033 and spring 914006 in center rotor hole. Wide: Use two 201105 on both sides. Then one 201160 on the right and one 201170 on the left. Replace the top two screws in the vend motor (8/32 x 1/4") with two 901038 (8/32 x 1/2) if sold out paddles are not present. Load Caps to the rear. See Instructions Section G

BEFORE WORKING ON VENDER:

Remove power from vender by unplugging vender's main power cord from the AC voltage power source.

INSTRUCTIONS:

(A) GIII 1463 & after

1. Remove all products from the columns being converted.
2. Adjust product stops to vend small packages.
3. Set product retainers and back spacers: Front hole #12, Rear #8.
4. Set SDEP option to "1" (Single Depth).
5. Test vend to ensure product vends properly.

Note: Make sure bottles are loaded caps to front in front columns and caps to the rear in rear columns.

(B) GIII prior to 1463:

1. Remove all products from the columns being converted.
2. Adjust product stops to vend small packages.
3. Set product retainers and back spacers: Front hole #11, Rear #8.
4. Set SDEP option to "1" (Single Depth).
5. Test vend to ensure product vends properly.

Note: Make sure bottles are loaded caps to front in front columns and caps to the rear in rear columns.

**ANY QUESTIONS??? CONTACT ROYAL VENDORS' CUSTOMER SERVICE DEPARTMENT
 CALL TOLL FREE (800) 931-9214**



012

Package Vending Specification

426 Industrial Boulevard • Kearneysville WV 25430-2776
Phone: (304) 728-7056 • Fax: (304) 725-6579

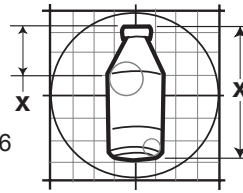

PAGE: 3 of 4

DATE: 12-3-03

REVISION: 01

PRODUCT NAME: Powerade 12 oz.

(C) GII

1. Remove all products from the columns being converted.
2. Set the rear retainer to the front position.
3. Set rocker switch #4 on Vender Controller Switch Module" to ON for bottles.
4. Test vend to ensure product vends properly.

Note: The 12 oz POWERaDE bottle can only be vended out of the rear column with caps towards the rear.

(D) 3 Deep, prior to 1352:

1. Remove all products from the columns being converted.
2. Set SDEP option to "2" (Double Depth).
3. Set the rear retainer to #9 (counting back to front) for both narrow and wide columns.
4. Test vend to ensure product vends properly.

Note: Load wide columns butt to butt. Caps to rear in narrow columns.

(E) 3 Deep+:

1. Remove all products from the columns being converted.
2. Set SDEP option to "2" (Double Depth).
3. Set the rear retainer to #9 (counting back to front) for both narrow and wide columns.
4. Test vend to ensure product vends properly.

Note: Load wide columns butt to butt. Caps to rear in narrow columns.

(F) 3 Deep, 16 oz. (510, 609, 540, 630)

1. Remove all products from the columns being converted.
2. Set SDEP option to "2" (Double Depth) for narrow columns and "1" (Single Depth) for wide columns.
3. Install shims into columns:

For narrow columns use two shims on the right side. (058135) goes in first against column wall and then add (201,101) on top of previous shim. Also install shim rod (803009) & spring (914006) into the center hole of rotor.

For wide columns use weld assembly (058180) on right column wall and weld assembly (058190) on left column wall. In conjunction with the weld assemblies, use flat shim (058105) on both sides. The flat shim fits between the column wall and the weld assembly shim on both sides.

Replace the # 8/32 x 1/4" machine screws in the two top holes of the vend motor mounting bracket with # 8/32 x 1/2" machine screws (901038). Add these only if sold out paddles are not present. The purpose of these screws is to push the bottom tie strip further out into the column and keep the product from getting caught on the front end of the oscillator. (See Figure 1, next page)

4. Set the rear retainer to #9 (counting back to front) for narrow columns and #19 for wide columns.
5. Test vend to ensure product vends properly.

Note: Load bottles with caps towards rear.

**ANY QUESTIONS??? CONTACT ROYAL VENDORS' CUSTOMER SERVICE DEPARTMENT
CALL TOLL FREE (800) 931-9214**



012

Package Vending Specification

426 Industrial Boulevard • Kearneysville WV 25430-2776
Phone: (304) 728-7056 • Fax: (304) 725-6579

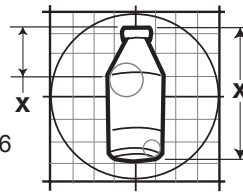

PAGE: 4 of 4
DATE: 12-3-03
REVISION: 01

PRODUCT NAME: Powerade 12 oz.

(G) 3 Deep+, 16 oz. (510, 609, 540, 630)

1. Remove all products from the columns being converted.
2. Set SDEP option to "2" (Double Depth) for narrow columns and "1" (Single Depth) for wide columns.
3. Install shims into columns:

For narrow columns use two shims on the right side. (201129) goes in first against the column wall and then add (201106) on top of previous shim. Also install shim rod (803033) & spring (914006) into the center hole of rotor.

For wide columns use weld assembly (201160) on right column wall and weld assembly (201170) on left column wall. In conjunction with the weld assemblies, use flat shim (201105) on both sides. The flat shim fits between the column wall and the weld assembly shim on both sides.

Replace the # 8/32 x 1/4" machine screws in the two top holes of the vend motor mounting bracket with # 8/32 x 1/2" machine screws (901038). Add these only if sold out paddles are not present. The purpose of these screws is to push the bottom tie strip further out into the column and keep the product from getting caught on the front end of the oscillator. (See Figure 1, below)

4. Set the rear retainer to #9 (counting back to front) for narrow columns and #19 for wide columns.
5. Test vend to ensure product vends properly.

Note: Load bottles with caps towards rear.

(H) 2 Deep:

Note: The Powerade 12 oz. bottle cannot be vended reliably in electronic 2 Deep venders. It does vend reliably in 2 Deep Electromechanical venders.

1. Remove all products from the columns being converted.
2. Set cams to double depth.
3. Set the rear retainer to #1 (counting back to front) for both narrow and wide columns.
4. Test vend to ensure product vends properly.

Note: Caps to front in wide columns and then butt to butt. Caps to rear in narrow columns.

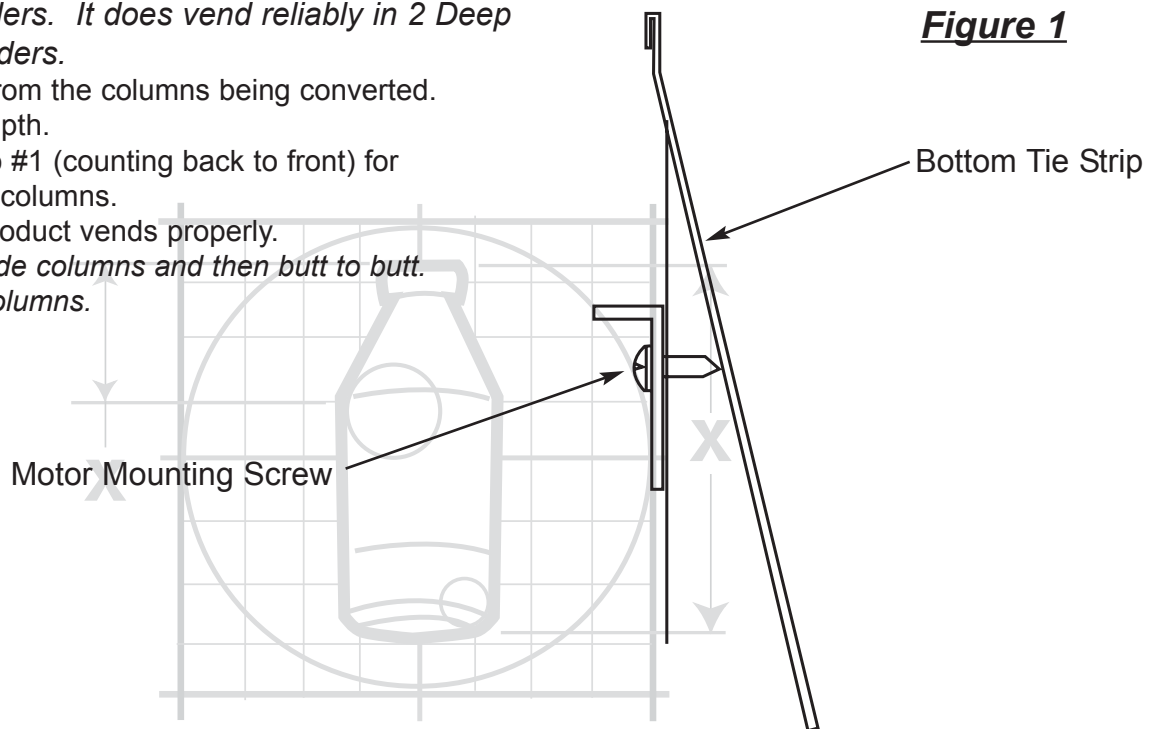

Figure 1

**ANY QUESTIONS??? CONTACT ROYAL VENDORS' CUSTOMER SERVICE DEPARTMENT
CALL TOLL FREE (800) 931-9214**