



Helpful Hints 0009

clear & easy

201 INDUSTRIAL BOULEVARD • KEARNEYSVILLE, WV 25430
Phone: (304) 728-7056 • Fax: (304) 725-6579 • Toll Free: (800) 931-9214

PAGE: 1 of 1

DATE: 9-13-01

REVISION: 02

SUBJECT: Removing a Sign from a Landscape Vender

of People Required 

MODELS: Landscape Venders

ESTIMATED TIME: 15 minutes

TOOLS NEEDED:

- | | |
|----------------------------------|-----------------|
| Socket Wrench w/
11/32 Socket | Electrical Tape |
| Drill w/ 1/4 Bit | 7/16 Wrench |
| | Rubber Mallet |

Instructions:

REMOVE SIGN

1. Power down vender.
2. Open Door.
3. Drill out (3) christmas trees.
4. Loosen all t-bolts on the right-hand side of trim (facing the inside of door) plus the top and bottom (2) t-bolts near the right side.
5. Take 4 bolts off port trim and loosen top 2. Remove can stop, port trim and port spacer. **See Figure 3**
6. Push sign out from the right side (facing inside door). Go around to front of the vender and pull sign out.

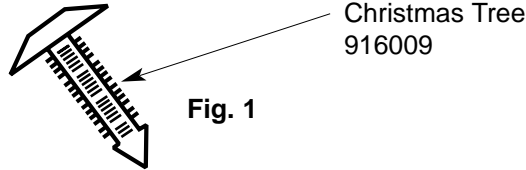

INSTALL NEW SIGN Remove any protective film, on either side of sign, prior to installation (if needed.)

1. Tape the port spacer to the port (same position as before).
2. Insert new sign from left to right (facing front of vender).
3. Tighten t-bolts along trim (start from the bottom).
4. Reinstall port trim and can stop.
5. Reinstall 4 bolts back on port.
6. Tighten top 2 bolts on port.
7. Rack door: insert a 1 x 1 x 3 wooden block at the bottom of door prior to drilling.
8. Close door with block and drill 3 holes in the new lexan sign for christmas trees.
9. Tap in christmas trees.
10. Check door for proper alignment.

Fig. 2

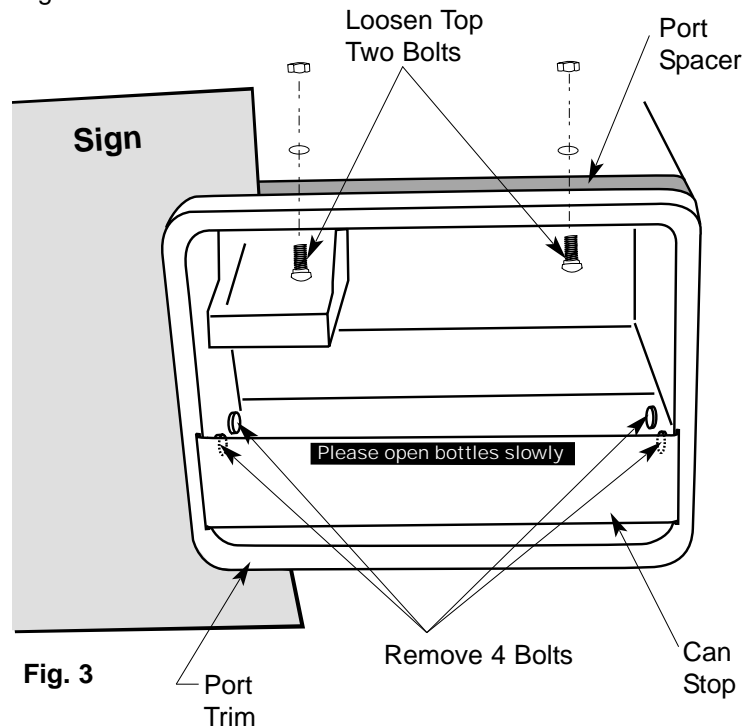
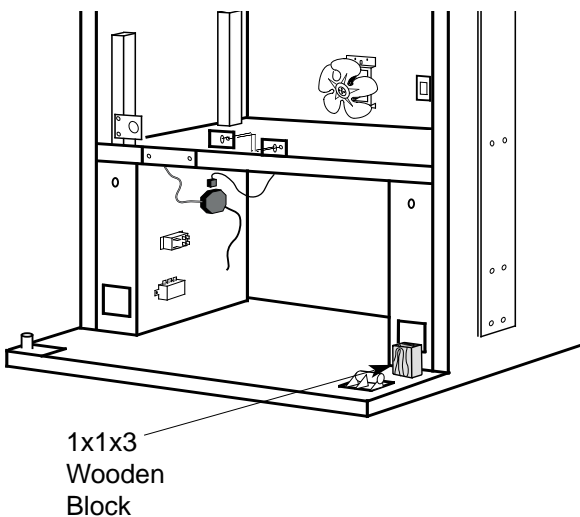

Fig. 3

ANY QUESTIONS??? CONTACT ROYAL VENDORS' CUSTOMER SERVICE DEPARTMENT
CALL TOLL FREE (800) 931-9214