



# SERVICE BULLETIN 348

426 Industrial Boulevard • Kearneysville WV 25430-2776 • USA  
 Telephone: +1 304 728 7056 • technicalinquiry@royalvenders.com  
 Toll-free in North America: 1 800 931 9214 • Fax: +1 304 725 4016  
 Canada: +1 905 738 5777 • Mexico: +52 55 5203 6887  
 Europe: +49 2158 95 1000 • Australia: +61 2 9890 5433

Page: 1 of 2

Date: 3 Aug 2011

Revision: 00

**SUBJECT:** RVV 500 Vertical Elevator Rail Replacement

**MODELS:** RVV 500

Number of  
People  
Required



KIT NUMBER	KIT DESCRIPTION
810312	Elevator Vertical Rail

**TOOLS REQUIRED:** Phillips screwdriver

**ESTIMATED INSTALLATION TIME:** 3 minutes



The following areas of this vender contain voltage which can cause serious injury or even death: the main power cord, supplying 115-230 VAC to the evaporator, EMI filter, and refrigeration system; the power line from the EMI filter to the ballast and transformer; and the ballast, which can produce upwards of 600 volts. Remove all power from the vender before working in any of these areas.

**BACKGROUND INFORMATION:** Some defective vertical elevator rails were discovered which may rust prematurely. This rust does not affect function, but could be unsightly. This bulletin describes the most efficient procedure for replacing these rails.

### INSTALLATION INSTRUCTIONS:

**NOTE:** If both vertical rails are to be replaced, it is recommended to do only one at a time.

1. Remove power by unplugging the vender's power cord from the AC voltage source (wall outlet).
2. Lift the elevator arm approximately half-way.
3. Using a Phillips screwdriver, remove the bottom screw in the rail. (See Figure 1.)
4. Lower the elevator arm all the way.
5. Remove the rest of the screws that secure the rail. (See Figure 2.)
6. Lift the vertical rail out of the door, angling it slightly to clear the door chassis.
7. Install the new rail. Make sure the rail slides onto the rollers of the elevator arm. (See Figures 3 and 4.)
8. Secure the new rail with the screws that were removed in Steps 3 and 5, beginning with the top. Lift the elevator arm to access the bottom screw hole.
9. Restore power by plugging the vender's power cord into the AC voltage source (wall outlet).
10. Close the vender's door and vend cells 11, 18, 51, and 58 to ensure correct elevator function.

### Figure 1.

As shown here, the elevator arm is moved up out and of the way so the bottom screw in the vertical rail can be accessed.



In an effort to provide our customers with the latest information on our equipment, Royal Vendors sends service bulletins to customers using the original ship-to address or e-mail addresses, if supplied by our customers. We also post all service bulletins on our website at [www.royalvenders.com](http://www.royalvenders.com). If for any reason a vender is moved to another location or is sold to another customer other than to whom Royal Vendors originally sent the machine, it is the responsibility of the original purchaser of the vender to notify the appropriate personnel of the service bulletin.

**ANY QUESTIONS? CONTACT ROYAL VENDORS' CUSTOMER SERVICE DEPARTMENT  
 IN NORTH AMERICA, CALL TOLL FREE 1 800 931 9214**



# SERVICE BULLETIN 348

426 Industrial Boulevard • Kearneysville WV 25430-2776 • USA  
Telephone: +1 304 728 7056 • technicalinquiry@royalvendors.com  
Toll-free in North America: 1 800 931 9214 • Fax: +1 304 725 4016  
Canada: +1 905 738 5777 • Mexico: +52 55 5203 6887  
Europe: +49 2158 95 1000 • Australia: +61 2 9890 5433

Page: 2 of 2

Date: 3 Aug 2011

Revision: 00

**SUBJECT:** RVV 500 Vertical Elevator Rail Replacement

**MODELS:** RVV 500

**Figure 2.**

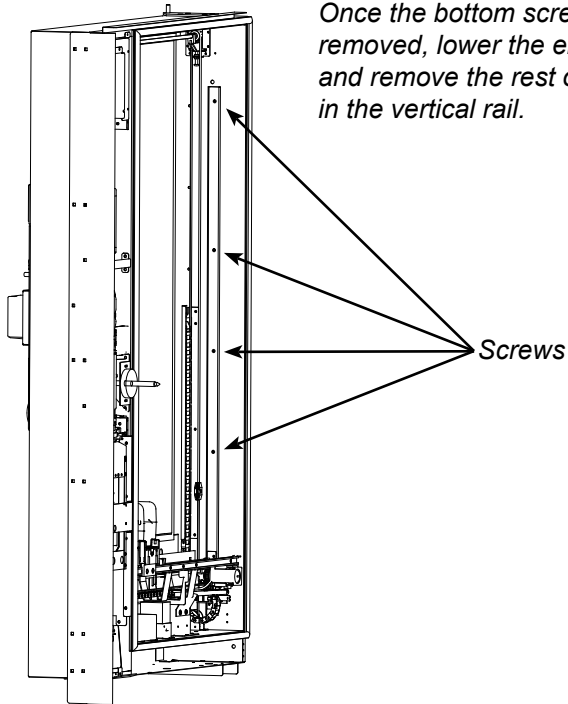

Once the bottom screw has been removed, lower the elevator arm and remove the rest of the screws in the vertical rail.

**Figure 3.**

As shown, it will be necessary at first to angle the rail to get it in the door.



**Figure 4.**



Left side

Ensure the rails slide onto the rollers of the elevator arm. All four rollers on each side of the elevator arm should be securely with the flanges of the rail.



Right side

**ANY QUESTIONS? CONTACT ROYAL VENDORS' CUSTOMER SERVICE DEPARTMENT  
IN NORTH AMERICA, CALL TOLL FREE 1 800 931 9214**