



SERVICE BULLETIN 319

426 Industrial Boulevard • Kearneysville WV 25430-2776 • USA
 Telephone: +1 304 728 7056 • technicalinquiry@royalvenders.com
 Toll-free in North America: 1 800 931 9214 • Fax: +1 304 725 4016
 Canada: +1 905 738 5777 • Mexico: +52 55 5203 6887
 Europe: +49 2158 95 1000 • Australia: +61 2 9890 5433

Page: 1 of 2

Date: 6 Apr 10

Revision: 00

SUBJECT: Pepsi Select Panel Fascia Replacement

MODELS: Pepsi RVV 500

Number of
People
Required



KIT NUMBER

KIT DESCRIPTION

356060	Pepsi Fascia Conversion Kit RVV NG
356061	Mt Dew Fascia Conversion Kit RVV NG
356062	Gatorade Fascia Conversion Kit RVV NG
356063	Aquafina Fascia Conversion Kit RVV NG

TOOLS REQUIRED: Drill with 3/8" (9 mm) bit

ESTIMATED INSTALLATION TIME: <10 minutes

REASON FOR BULLETIN: This kit allows the new double-validator fascia to be installed onto an older single-validator fascia door.



The following areas of this vender contain voltage which can cause serious injury or even death: the main power cord, supplying 115-230 VAC to the evaporator, EMI filter, and refrigeration system; the power line from the EMI filter to the ballast and transformer; and the ballast, which can produce upwards of 600 volts. Remove all power from the vender before working in any of these areas.

INSTALLATION INSTRUCTIONS:

1. Remove the existing select panel fascia from the vender's door.
2. Align the cutout in the drill template with the validator or validator cutout in the vender's door. (Refer to Figure 1.) Mark the template drill holes with a pencil or other instrument. Remove the template.
3. Using a 3/8" (9 mm) bit, drill the holes that were just marked in the vender's door.
4. Mount the fascia on the vender's door and secure it using the original Keps nuts from the old fascia, plus one Keps nut from the kit.
5. Align the filler plate with the top of the cutout in the vender's fascia. (Refer to Figure 2.) Mark the holes for the carriage bolts on the side of the door. Remove the filler plate.
6. Using a 3/8" (9 mm) bit, drill the holes that were just marked in the vender's door.
7. Mount the filler plate. Secure it with the two carriage bolts and two of the Keps nuts from the kit.

In an effort to provide our customers with the latest information on our equipment, Royal Vendors sends service bulletins to customers using the original ship-to address or e-mail addresses, if supplied by our customers. We also post all service bulletins on our website at www.royalvenders.com. If for any reason a vender is moved to another location or is sold to another customer other than to whom Royal Vendors originally sent the machine, it is the responsibility of the original purchaser of the vender to notify the appropriate personnel of the service bulletin.

**ANY QUESTIONS? CONTACT ROYAL VENDORS' CUSTOMER SERVICE DEPARTMENT
 IN NORTH AMERICA, CALL TOLL FREE 1 800 931 9214**



SERVICE BULLETIN 319

426 Industrial Boulevard • Kearneysville WV 25430-2776 • USA
Telephone: +1 304 728 7056 • technicalinquiry@royalvendors.com
Toll-free in North America: 1 800 931 9214 • Fax: +1 304 725 4016
Canada: +1 905 738 5777 • Mexico: +52 55 5203 6887
Europe: +49 2158 95 1000 • Australia: +61 2 9890 5433

Page: 2 of 2

Date: 6 Apr 10

Revision: 00

SUBJECT: Pepsi Select Panel Fascia Replacement

MODELS: Pepsi RVV 500

Figure 1.

Align the cutout in the drill template with the validator or validator cutout in the vender's door. Mark the drill holes with a pencil or other instrument.

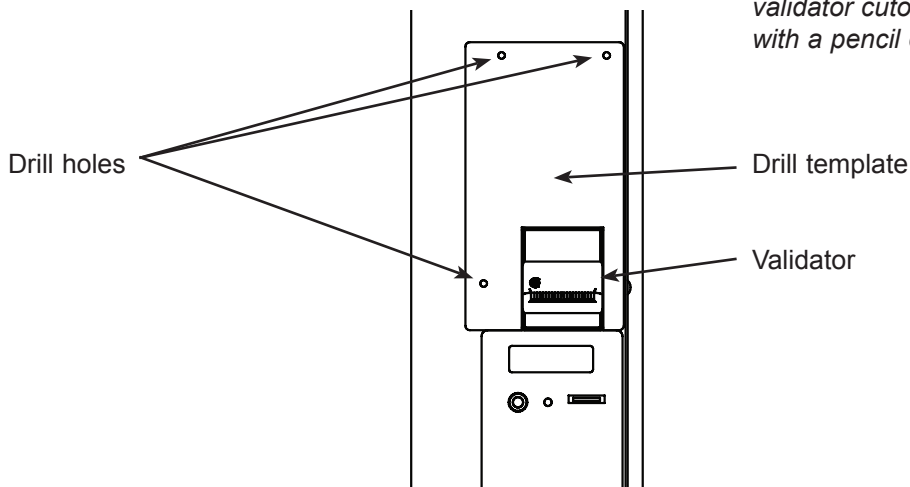
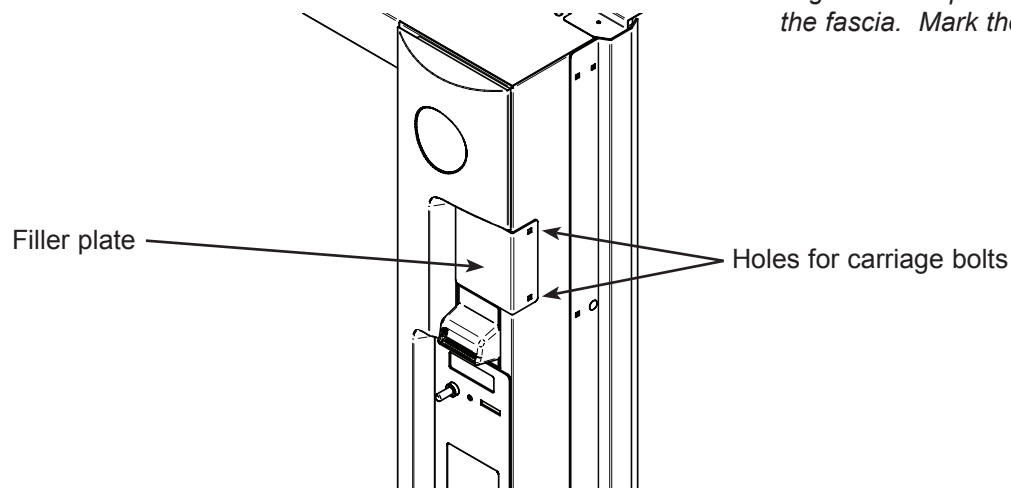

Figure 2.

Align the filler plate with the top of the cutout in the fascia. Mark the holes for the carriage bolts.



**ANY QUESTIONS? CONTACT ROYAL VENDORS' CUSTOMER SERVICE DEPARTMENT
IN NORTH AMERICA, CALL TOLL FREE 1 800 931 9214**