



SERVICE BULLETIN 298

426 Industrial Boulevard • Kearneysville WV 25430-2776 • USA
 Telephone: +1 304 728 7056 • technicalinquiry@royalvenders.com
 Toll-free in North America: 1 800 931 9214 • Fax: +1 304 725 4016
 Canada: +1 905 738 5777 • Mexico: +52 55 5203 6887
 Europe: +49 2158 95 1000 • Australia: +61 2 9890 5433

Page: 1 of 4

Date: 19 May 09

Revision: 02

SUBJECT: Interlock Upgrade Kit Installation Instructions

Number of
People
Required



MODELS: RVV 500

KIT NUMBER	KIT DESCRIPTION
356050	Interlock Upgrade Kit (Partial)

TOOLS REQUIRED: Phillips screwdriver; 7/16", 11/32", and 3/8" sockets with long extension

ESTIMATED INSTALLATION TIME: 30 minutes

REASON FOR BULLETIN: Some RVV 500 models may experience locking of the port box due to customers continuously trying to open the product bin prior to delivery of the product to the port box. A kit has been developed to relieve this type of activity so that the interlock will not lock prematurely.



The following areas of this vender contain voltage which can cause serious injury or even death: the main power cord, supplying 115-230 VAC to the evaporator, EMI filter, and refrigeration system; the power line from the EMI filter to the ballast and transformer; and the ballast, which can produce upwards of 600 volts. Remove all power from the vender before working in any of these areas.

INSTALLATION INSTRUCTIONS:

1. Remove power by unplugging the vender's power cord from the AC voltage source (wall outlet).
2. Open the vender's door, and remove the coin box.
3. Using a 7/16" wrench, remove the nuts on the three carriage bolts that secure the coin box housing in the vender's door. Remove the carriage bolts, and then remove the coin box housing. (Refer to Figure 1.)
4. Using an 11/32" socket with long extension, remove the four nuts that secure the port box assembly. Two of these nuts are above the assembly; the other two are accessible about mid-way down the assembly by way of semi-circular cutouts in the adjacent brackets mounted to the vender's door. (Refer to Figure 2.)
5. Disconnect the harness that goes to the detector board on the port box assembly.
6. *Venders with TriTeq locks:* Remove the battery backup jack, located in the top of the delivery bin.
7. Remove the port box housing assembly from the vender.
8. Disconnect the harness on the gate switch.
9. Using a 3/8" socket, remove the four nuts that secure the port door & slide assembly (two above and two below). (Refer to Figure 3.)
10. Remove the port door & slide assembly from the vender.
11. Remove both springs from the port door & slide assembly that was just removed from the vender.
12. At the bottom of the port door & slide assembly is a tab that bends out to prevent the delivery door from sliding down too far. Bend this tab in so that the delivery door can slide past this tab. (Refer to Figure 4.)
13. Slide the delivery door down to the notches to allow removal of this delivery door. (Refer to Figure 4.)
14. Remove the bushings from the delivery door that was just removed. (Refer to Figure 5.)
15. Install the bushings on the new delivery door from the kit.
16. Insert the delivery door into the notches on the door slide.
17. Install the new springs from the kit on the port door & slide assembly, replacing the ones that were removed in Step 11.
18. Slide the door up and down to ensure it slides freely, without resistance.
19. Bend the tab out to prevent the new delivery door from sliding down all the way.
20. Reconnect the gate switch harness.
21. Reinstall the port door & slide assembly in the vender's door by angling and inserting it.
22. Secure the port door & slide assembly in the vender with the four bolts that were removed in Step 9.
23. Lay the port box housing assembly flat on its left side. Then, remove the eight screws that secure the left housing

In an effort to provide our customers with the latest information on our equipment, Royal Vendors sends service bulletins to customers using the original ship-to address or e-mail addresses, if supplied by our customers. We also post all service bulletins on our website at www.royalvenders.com. If for any reason a vender is moved to another location or is sold to another customer other than to whom Royal Vendors originally sent the machine, it is the responsibility of the original purchaser of the vender to notify the appropriate personnel of the service bulletin.

**ANY QUESTIONS? CONTACT ROYAL VENDORS' CUSTOMER SERVICE DEPARTMENT
IN NORTH AMERICA, CALL TOLL FREE 1 800 931 9214**



SERVICE BULLETIN 298

Page: 2 of 4

Date: 19 May 09

Revision: 02

426 Industrial Boulevard • Kearneysville WV 25430-2776 • USA
Telephone: +1 304 728 7056 • technicalinquiry@royalvendors.com
Toll-free in North America: 1 800 931 9214 • Fax: +1 304 725 4016
Canada: +1 905 738 5777 • Mexico: +52 55 5203 6887
Europe: +49 2158 95 1000 • Australia: +61 2 9890 5433

SUBJECT: Interlock Upgrade Kit Installation Instructions

MODELS: RVV 500

assembly to the port box assembly. (Refer to Figure 6.) Lift the left housing assembly straight up off the port box assembly.

24. Remove the existing port box from the housing assembly. (Refer to Figure 7.)
25. Install the new port box from the kit in place of the old one.
26. Replace the port bushings with new ones from the kit. (Refer to Figure 8.) **Note:** This is a preventative measure, as the bushings will wear over time or with heavy usage.
27. Install the new left housing assembly in place of the one that was removed in Step 23. Secure it with the eight screws that previously secured the old left housing assembly.
28. Install the port box assembly in the vender's door. Ensure that the harnesses in the door are not caught behind the port box assembly, pinched, bound up, etc. Hold down the delivery door while installing the port box assembly.
29. Secure the port box housing assembly with the four nuts that were removed in Step 4.
30. Reconnect the harness to the detector board.
31. *Venders with TriTeq locks:* Reinstall the battery backup jack in the top of the port box assembly.
32. Reinstall the coin box housing. Secure it with the three carriage bolts and nuts that were removed in Step 3.
33. Reinstall the coin box.
34. Using the self-drilling screws from the kit, install the port spacer in the location shown in Figure 9.
35. Open and close the port box several times to ensure that it does not bind.
36. Restore power to the vender by plugging the vender's power cord into the AC voltage source.

Figure 1.

Remove the nuts on these carriage bolts, accessible from inside the door. Then, remove the carriage bolts and the coin box housing.

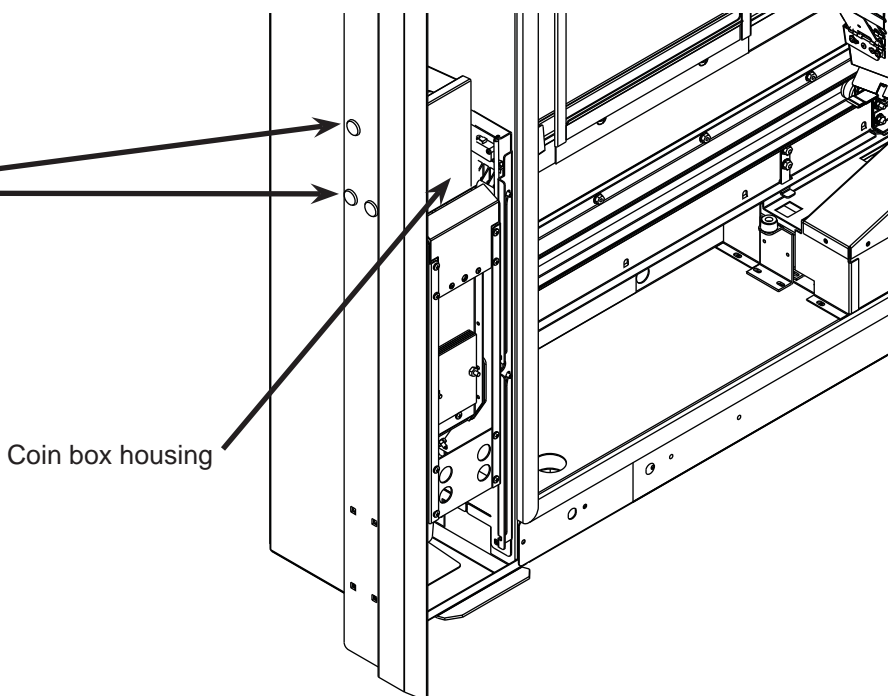

**ANY QUESTIONS? CONTACT ROYAL VENDORS' CUSTOMER SERVICE DEPARTMENT
IN NORTH AMERICA, CALL TOLL FREE 1 800 931 9214**

SUBJECT: Interlock Upgrade Kit Installation Instructions

MODELS: RVV 500

Figure 2.

Remove the four nuts that secure the port box housing assembly. A long socket extension will be required.

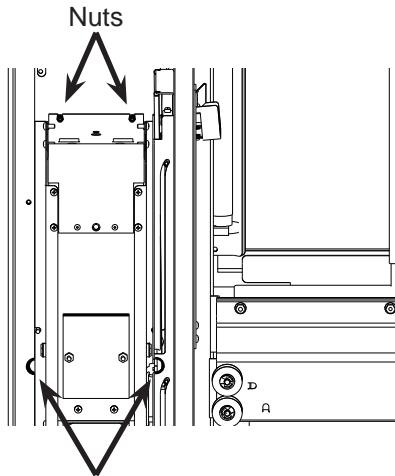

To reach the bottom nuts, use these access notches.

Figure 3.

Remove the four nuts that secure the port door & slide assembly.

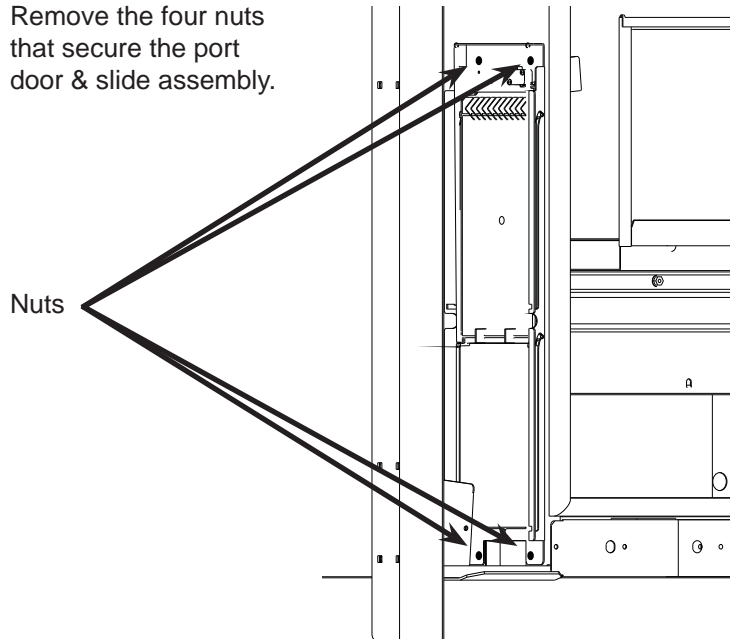

Figure 4.

Slide the delivery door down so that the knobs on each side of it can be removed through these notches in the port slide assembly.

This tab will be bent out to prevent the delivery door from sliding too far down. Bend this tab in to allow the door to slide down for removal.

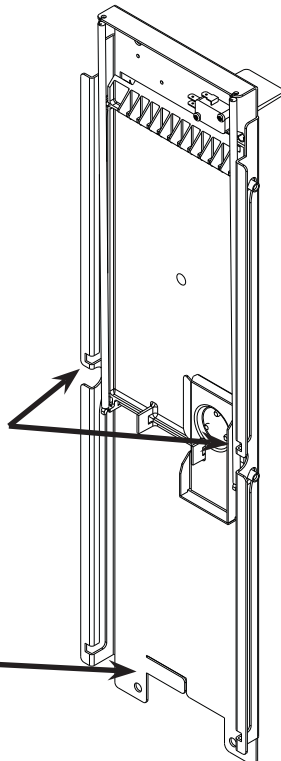
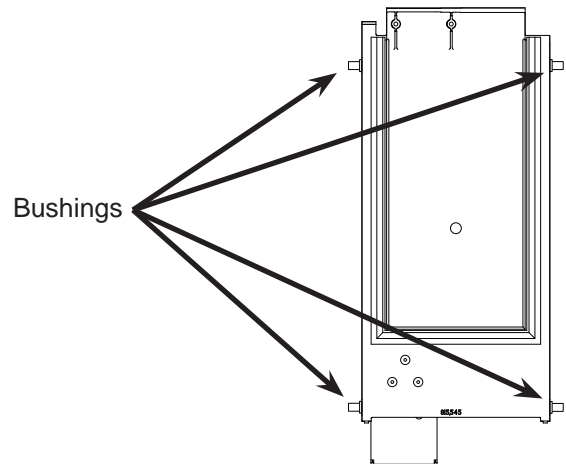

Figure 5.

Remove the bushings from the delivery door.



ANY QUESTIONS? CONTACT ROYAL VENDORS' CUSTOMER SERVICE DEPARTMENT IN NORTH AMERICA, CALL TOLL FREE 1 800 931 9214

SUBJECT: Interlock Upgrade Kit Installation Instructions

MODELS: RVV 500

Figure 6.

Remove the eight screws (pointed out below) that secure the left housing assembly to the port box assembly.

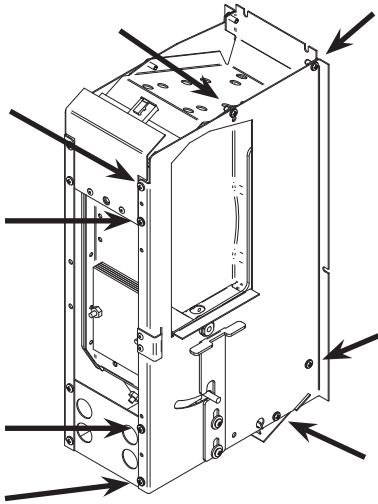

Figure 7.

Remove the existing port box and replace it with the new one from the kit.

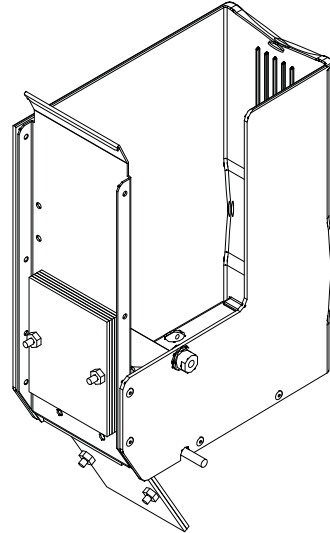
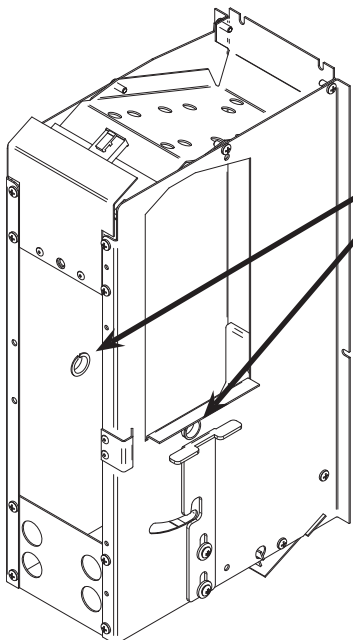

Figure 8.

Replace the port bushings.



Port bushings
There are two port bushings, one on each side of the port box housing.

Figure 9.

Install the port spacer.

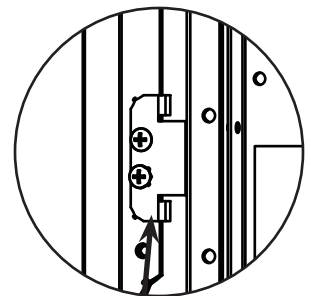
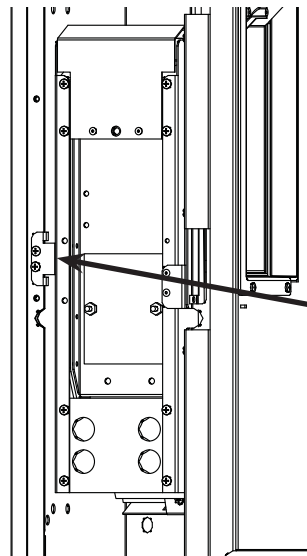

Port spacer
Install the port spacer as shown. Secure it with two screws from the kit.

**ANY QUESTIONS? CONTACT ROYAL VENDORS' CUSTOMER SERVICE DEPARTMENT
IN NORTH AMERICA, CALL TOLL FREE 1 800 931 9214**