



SERVICE BULLETIN # 00269

426 INDUSTRIAL BOULEVARD • KEARNEYSVILLE WV 25430-2776 • USA
Phone: +1 304 728-7056 • Fax: +1 304 725-6579 • Toll Free: 800 931-9214

PAGE: 1 of 5

DATE: 11-21-05

REVISION: 00

SUBJECT: Removal and Replacement of the RVV NG Product Cup

of People
Required



MODELS: All RVV NG venders

Part Number	Part Description
815588	Product Cup Assembly RVV NG

TOOLS REQUIRED: Phillips screwdriver, 11/32" open-end wrench, pliers (*a flashlight is also recommended*)

ESTIMATED TIME: 45 minutes

REASON FOR BULLETIN: This bulletin describes the proper procedure for removing and replacing the product cup on the Royal Vision Vender Next Generation (RVV NG).



The following areas of this vender contain voltage which can cause serious injury or even death: the main power cord, supplying 110 VAC to the evaporator, EMI filter, and refrigeration system; the power line from the EMI filter to the ballast and transformer; and the ballast, which can produce upwards of 600 volts. Remove power from vender before working in any of these areas.

INSTRUCTIONS:

1. Remove power to the vender by unplugging the vender's main power cord from the AC voltage source (wall outlet).
2. Remove the three screws that secure the cup floor. (See Figure 1.) Then, remove the floor.
3. Remove the screw inside the bottom of the product cup that secures the belt bracket. (See Figure 2.) Make sure to hold this bracket from the bottom, as it will fall out once the screw is removed. Once the bracket is removed, the belt will be loose.
4. Using pliers, bend down the tab that secures the harness on the bottom of the cup.
5. Remove the screw that secures the harness chain to the bottom of the cup. (See Figure 3.)
6. Disconnect the harness from position P1 on the product cup circuit board. (See Figure 4.) Remove the harness from the cup through the hole in the bottom.
7. Reinstall the cup base on the product cup assembly. **Note:** This is done to prevent the small parts inside the cup from falling out. These parts **will** fall out in the event the cup is tilted, turned over, or dropped.
8. Using an 11/32" wrench, remove the two end nuts on the rear track. (See Figure 5.)
9. Using a Phillips screwdriver, remove the two center screws on the front track. (See Figure 5.)
10. Flex the front track so that the front wheels on the product cup can be disengaged from the track. Then, angle the cup upward to remove the rear track from the brackets that hold it on each end. (See Figure 6.)
11. Once the rear track has been removed from the brackets, pick it up and slide the product cup off the end of the bar. (See Figure 7.)
12. Slide the new product cup onto the bar from which the old product cup was just removed.
13. Angle the cup and fit the rear track into the brackets at either end. Then, lower the front of the cup, flex the front track, and engage the front wheels on the product cup into the front track. **Note:** The wheel assemblies on the cup are somewhat fragile. Use caution not to break them when installing the new cup in the vender.
14. Secure the front track with the two center screws that were removed in Step 8.
15. Secure the rear track with the two nuts that were removed in Step 7.
16. Remove the three screws that secure the new cup floor. Then, remove the floor.
17. Route the harness into the bottom of the cup, and connect it to position P1 on the product cup circuit board.
18. Route the harness through the bracket on the cup bottom, and bend down the tab to secure the harness.
19. Secure the harness chain with the screw that was removed in Step 4.
20. Reinstall the X-axis belt. To install the belt, pull the left end of the belt to the belt bracket, and pull it so that the end of the belt is flush with the top end of the bracket. Place the bracket and belt together against the plastic to the left of the opening on the bottom of the cup, so that the belt is held onto the bracket securely. Next, pull the right side of the belt to the bracket so that the end of the belt is flush with the top end of the bracket. Then, push the bracket and both ends of the belt upward into the slot. Secure the bracket by replacing the screw that was removed in Step 3. (See Figure 8.)

(CONTINUED ON NEXT PAGE)

In an effort to provide our customers with the latest information on our equipment, Royal Vendors sends service bulletins to customers using the original ship-to address or e-mail addresses, if supplied by our customers. We also post all service bulletins on our website at www.royalvendors.com. If for any reason a vender is moved to another location or is sold to another customer other than to whom Royal Vendors originally sent the machine, it is the responsibility of the original purchaser of the vender to notify the appropriate personnel of the service bulletin.

**ANY QUESTIONS??? CONTACT ROYAL VENDORS' CUSTOMER SERVICE DEPARTMENT
CALL TOLL FREE (800) 931-9214**



SERVICE BULLETIN # 00269

426 INDUSTRIAL BOULEVARD • KEARNEYSVILLE WV 25430-2776 • USA
Phone: +1 304 728-7056 • Fax: +1 304 725-6579 • Toll Free: 800 931-9214

PAGE: 2 of 5

DATE: 11-21-05

REVISION: 00

SUBJECT: Removal and Replacement of the RVV NG Product Cup

MODELS: All RVV NG venders

21. Reinstall the cup floor, and secure it with the three screws that were removed in Step 15.
22. Restore power to the vender by plugging the vender's main power cord into the AC voltage source (wall outlet).
23. Test vend to ensure product reliability.

Figure 1. Top view of cup

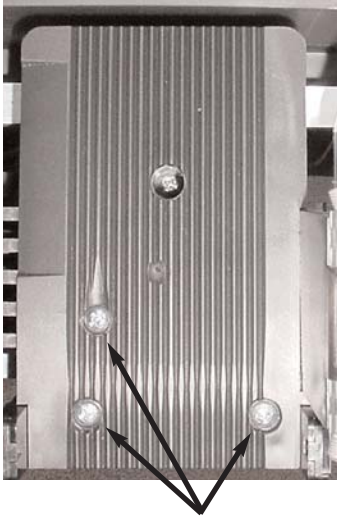

Remove these three screws that secure the cup floor.

Figure 2. Top view of product cup with cup floor removed

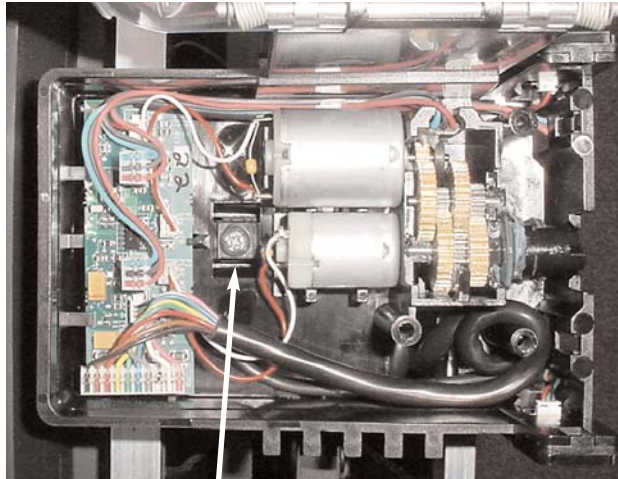

Remove this screw that secures the X-belt bracket.

Figure 3. Bottom of cup

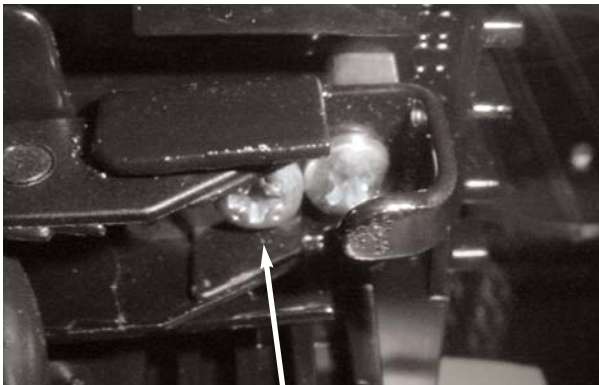

Remove this screw that secures the harness chain to the cup bottom.

Figure 4. Harness at Position P1

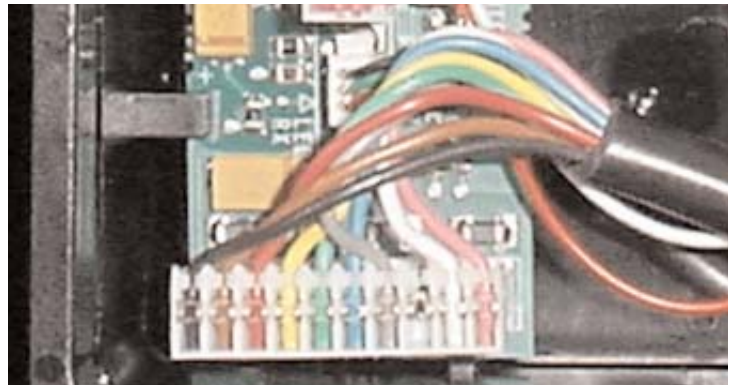

Remove this harness at Position P1 on the product cup circuit board.

ANY QUESTIONS??? CONTACT ROYAL VENDORS' CUSTOMER SERVICE DEPARTMENT
CALL TOLL FREE (800) 931-9214



SERVICE BULLETIN # 00269

426 INDUSTRIAL BOULEVARD • KEARNEYSVILLE WV 25430-2776 • USA
Phone: +1 304 728-7056 • Fax: +1 304 725-6579 • Toll Free: 800 931-9214

PAGE: 3 of 5
DATE: 11-21-05
REVISION: 00

SUBJECT: Removal and Replacement of the RVV NG Product Cup

MODELS: All RVV NG venders

Figure 5. Screws and nuts to be removed from tracks

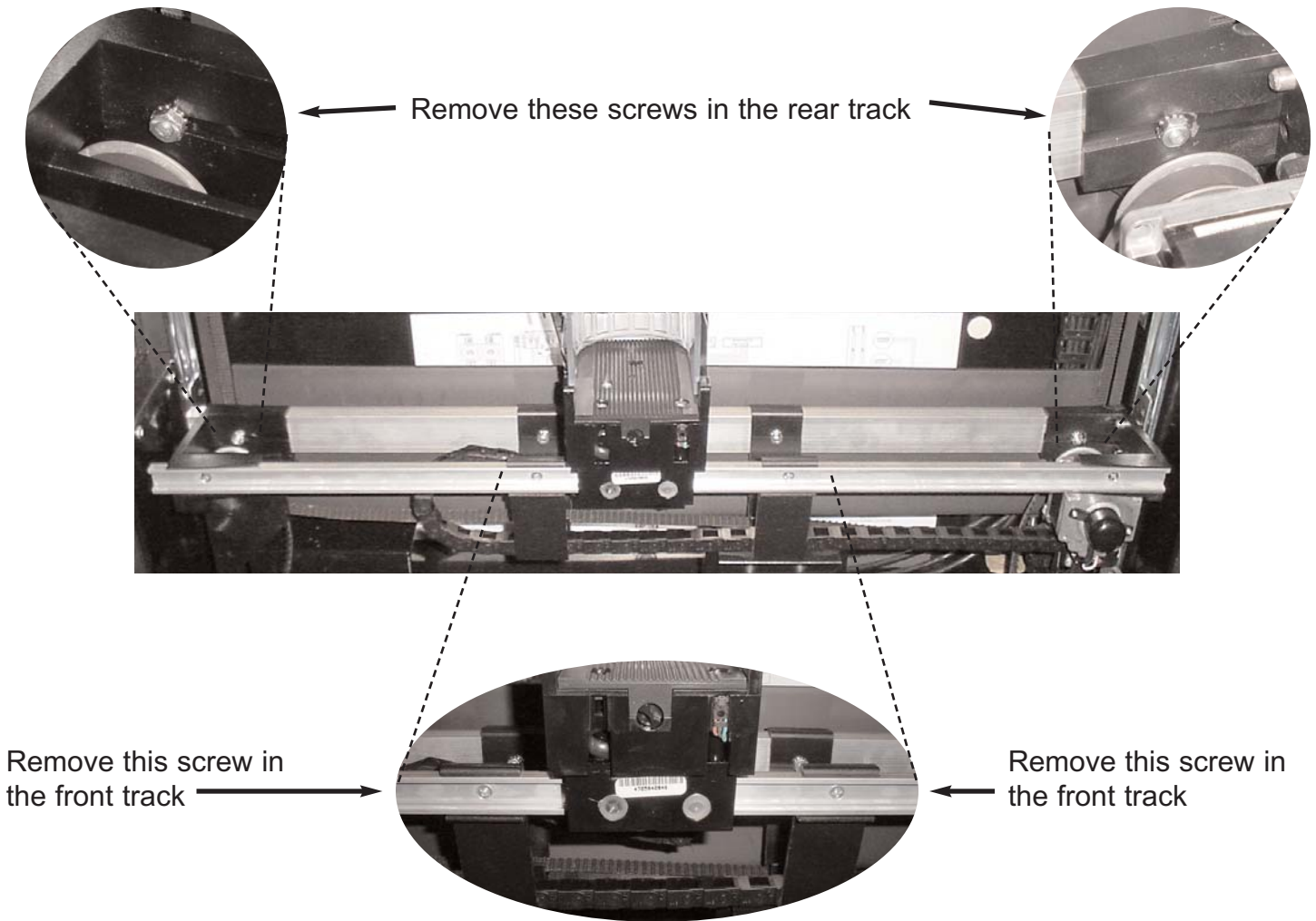

**ANY QUESTIONS??? CONTACT ROYAL VENDORS' CUSTOMER SERVICE DEPARTMENT
CALL TOLL FREE (800) 931-9214**



SERVICE BULLETIN # 00269

426 INDUSTRIAL BOULEVARD • KEARNEYSVILLE WV 25430-2776 • USA
Phone: +1 304 728-7056 • Fax: +1 304 725-6579 • Toll Free: 800 931-9214

PAGE: 4 of 5

DATE: 11-21-05

REVISION: 00

SUBJECT: Removal and Replacement of the RVV NG Product Cup

MODELS: All RVV NG venders

Figure 6. Disengaging product cup from front track

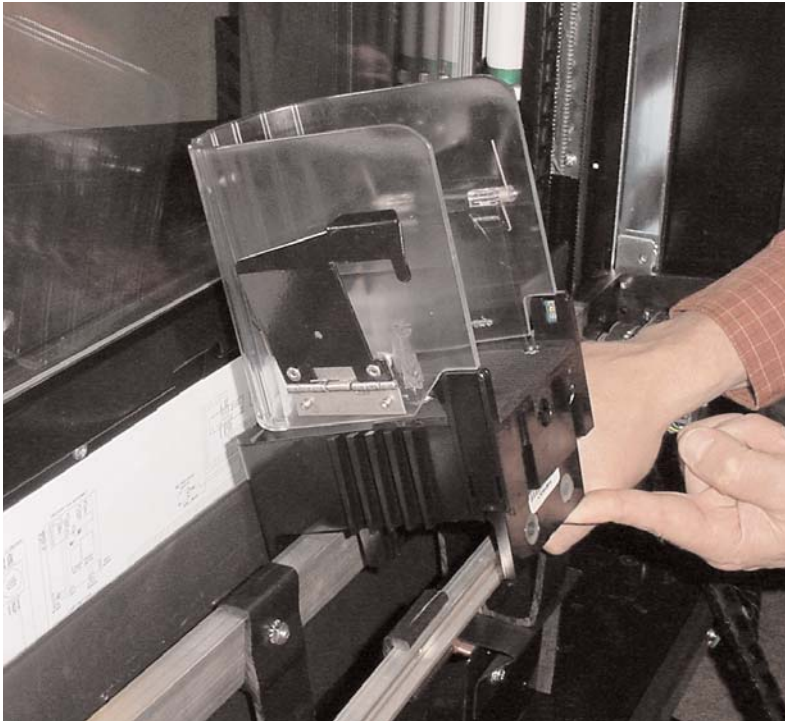

Flex the front track so that the front wheels on the product cup can be disengaged from the track. Then, angle the cup upward to remove the rear track from the brackets that hold it on each end.

Figure 7. Removing cup



Slide the cup off the end of the rear track to remove it from the vender.

**ANY QUESTIONS??? CONTACT ROYAL VENDORS' CUSTOMER SERVICE DEPARTMENT
CALL TOLL FREE (800) 931-9214**



SERVICE BULLETIN # 00269

426 INDUSTRIAL BOULEVARD • KEARNEYSVILLE WV 25430-2776 • USA
Phone: +1 304 728-7056 • Fax: +1 304 725-6579 • Toll Free: 800 931-9214

PAGE: 5 of 5

DATE: 11-21-05

REVISION: 00

SUBJECT: Removal and Replacement of the RVV NG Product Cup

MODELS: All RVV NG venders

Figure 8. Reinstalling the X-axis belt.

Reinstall the X-axis belt. To install the belt, pull the left end of the belt to the belt bracket, and pull it so that the end of the belt is flush with the top end of the bracket. Place the bracket and belt together against the plastic to the left of the opening on the bottom of the cup, so that the belt is held onto the bracket securely. Next, pull the right side of the belt to the bracket so that the end of the belt is flush with the top end of the bracket. Then, push the bracket and both ends of the belt upward into the slot. Secure the bracket by replacing the screw that was removed in Step 3.

The belt bracket slides upward into this slot in the bottom of the product cup.

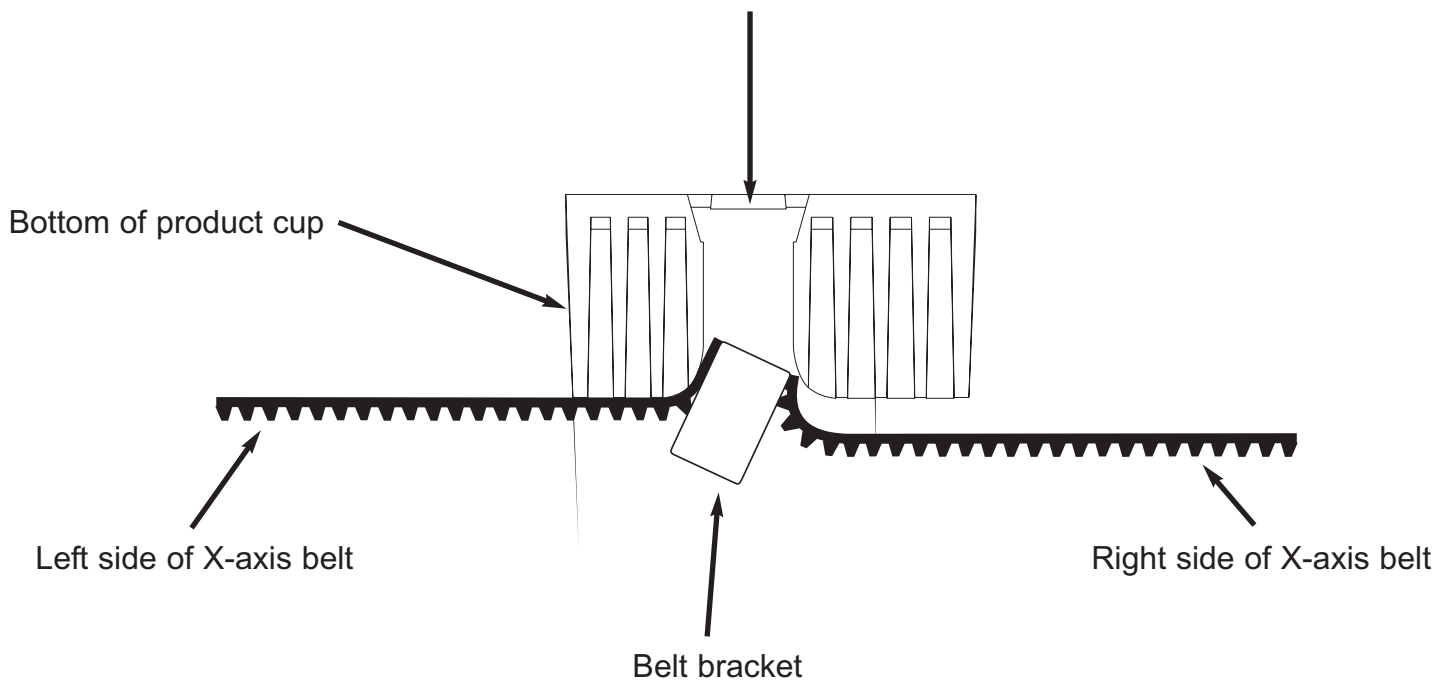

ANY QUESTIONS??? CONTACT ROYAL VENDORS' CUSTOMER SERVICE DEPARTMENT
CALL TOLL FREE (800) 931-9214