



# SERVICE BULLETIN 109

426 Industrial Boulevard • Kearneysville WV 25430-2776 • USA  
 Telephone: +1 304 728 7056 • technicalinquiry@royalvendors.com  
 Toll-free in North America: 1 800 931 9214 • Fax: +1 304 725 4016  
 Canada: +1 905 738 5777 • Mexico: +52 55 5203 6887  
 Europe: +49 2158 95 1000 • Australia: +61 2 9890 5433

Page: 1 of 3

Date: 31 Jan 11

Revision: 10

**SUBJECT:** Installation of Heater Kit

Number of  
People  
Required



**MODELS:** Merlin III, GII VII, GIII, Merlin IV, TDV, HVV

**KIT NUMBER**      **KIT DESCRIPTION**

141130      Heater Pad Kit

**TOOLS REQUIRED:**

Phillips screwdriver, 3/8" (3 mm) socket, wire cutters

**ESTIMATED INSTALLATION TIME:** <10 minutes

**REASON FOR BULLETIN:** The heater pad kit is designed to prevent products from freezing inside the vender in cold climates. This bulletin describes the proper procedure for installing the kit.

*NOTE: Some older types of venders (such as GII) are manufactured without the electronic refrigeration control system. See Service Bulletin 143 for conversion from thermostat to electronic refrigeration control system. This is only necessary if the vender is not currently equipped with the electronic system.*

## INSTALLATION INSTRUCTIONS:

1. Remove power by unplugging the vender's power cord from the AC voltage source (wall outlet).
2. Loosen the lower 1/4"-20 screw on the right front mechanism support.
3. Mount the heater pad housing assembly and secure it to the right front mechanism support, as shown in Figure A. Fasten it using the screw that was removed in Step 2.
4. **200722 and after:** Route the wiring harness behind the product chute. Unplug the two evaporator fan lead receptacles of the main wiring harness from the two evaporator fan motor tabs and evaporator fan relay leads. Plug these two receptacles into the tabs from the heater jumper harness. Plug the receptacles from the heater jumper harness to the two tabs from the evaporator fan motor and evaporator fan relay. Refer to Figure E, which shows the connections before and after installation of the heater kit.  
**200721 and before:** Route the wiring harness behind the product chute. Unplug the evaporator fan motor from the main wiring harness. Take the heater jumper leads and plug them into the mating leads from the evaporator fan motor and main wiring harness. Refer to Figure B.
5. Remove the two screws that hold the wiring cover plate in place. (This part covers the refrigeration tubing and wiring harnesses entering the cabinet, at the bottom left side of the cabinet.) Place the heater pad control leads in the cabinet's hat section. Reinstall the wiring cover plate. Refer to Figure C.
6. Using the supplied wire ties, tie the heater jumper and the heater pad control leads together under the product chute. Refer to Figure C.
7. Run the heater pad control leads with the existing door / cabinet harnesses to the main control board area. Wire-tie this in place to keep the harnesses clear of obstructions.
8. Remove the circuit board cover (if any). Locate the control board connector for the door-side relay harness, and unplug it from the control board. Using the supplied door-side heater relay harness, plug the black wire (ZX5) into position 2 of the connector just unplugged from the control board. This black wire (ZX5) should be between the black (ZX1) and red (ZX3) wires. Refer to Figure D.
9. Locate the four-way Mate-N-Lok connector, which is part of the door-side refrigeration relay harness (near the control board connector). Unplug the four-way connector. Plug the red wire (FT2) into position 2 of the four-way Mate-N-Lok plug (next to white wire FT1), as shown in Figure D.
10. Reconnect the four-way Mate-N-Lok plug / cap. Reconnect the door-side relay harness to the control board. Replace the circuit board cover (if any).
11. Ensure that all connections are secure before power is restored to the vender.
12. Test the evaporator fan motor and heater kit for proper function in relay test mode.



The following areas of this vender contain voltage which can cause serious injury or even death: the main power cord, supplying 115-230 VAC to the evaporator, EMI filter, and refrigeration system; the power line from the EMI filter to the ballast and transformer; and the ballast, which can produce upwards of 600 volts. Remove all power from the vender before working in any of these areas.

In an effort to provide our customers with the latest information on our equipment, Royal Vendors sends service bulletins to customers using the original ship-to address or e-mail addresses, if supplied by our customers. We also post all service bulletins on our website at [www.royalvendors.com](http://www.royalvendors.com). If for any reason a vender is moved to another location or is sold to another customer other than to whom Royal Vendors originally sent the machine, it is the responsibility of the original purchaser of the vender to notify the appropriate personnel of the service bulletin.

**ANY QUESTIONS? CONTACT ROYAL VENDORS' CUSTOMER SERVICE DEPARTMENT  
IN NORTH AMERICA, CALL TOLL FREE 1 800 931 9214**



# SERVICE BULLETIN 109

426 Industrial Boulevard • Kearneysville WV 25430-2776 • USA  
 Telephone: +1 304 728 7056 • technicalinquiry@royalvenders.com  
 Toll-free in North America: 1 800 931 9214 • Fax: +1 304 725 4016  
 Canada: +1 905 738 5777 • Mexico: +52 55 5203 6887  
 Europe: +49 2158 95 1000 • Australia: +61 2 9890 5433

Page: 2 of 3

Date: 31 Jan 11

Revision: 10

**SUBJECT:** Installation of Heater Kit

**MODELS:** Merlin III, GII VII, GIII, Merlin IV, TDV, HVV

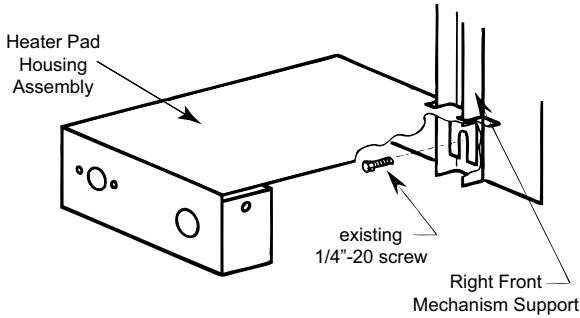

**FIGURE A**

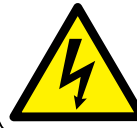

The following areas of this vender contain voltage which can cause serious injury or even death: the main power cord, supplying 115-230 VAC to the evaporator, EMI filter, and refrigeration system; the power line from the EMI filter to the ballast and transformer; and the ballast, which can produce upwards of 600 volts. Remove all power from the vender before working in any of these areas.

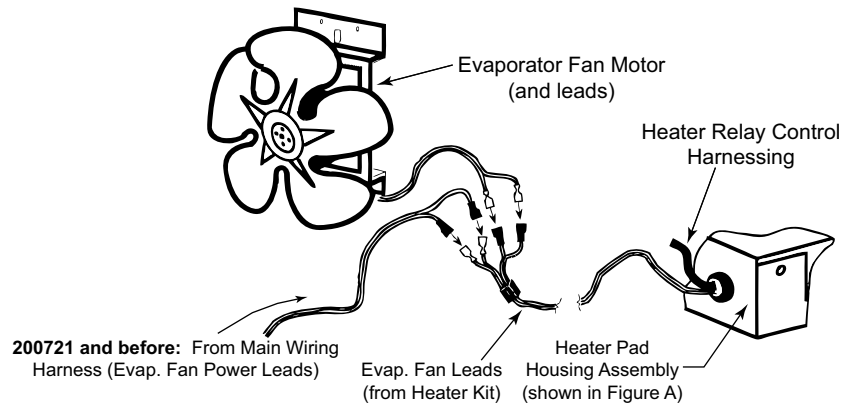

**FIGURE B**

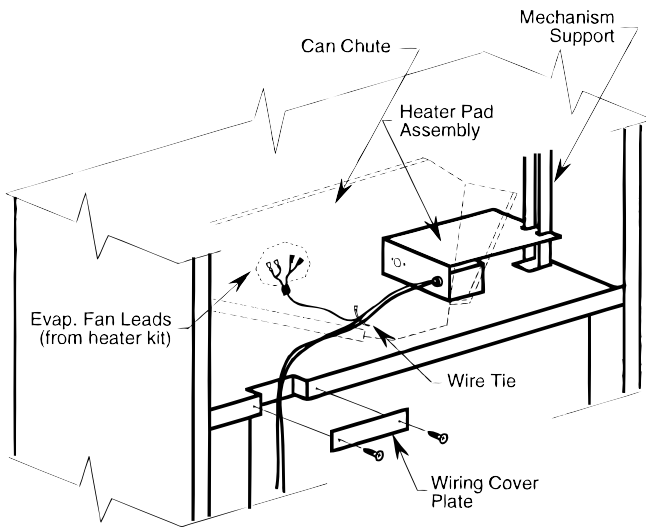

**FIGURE C**

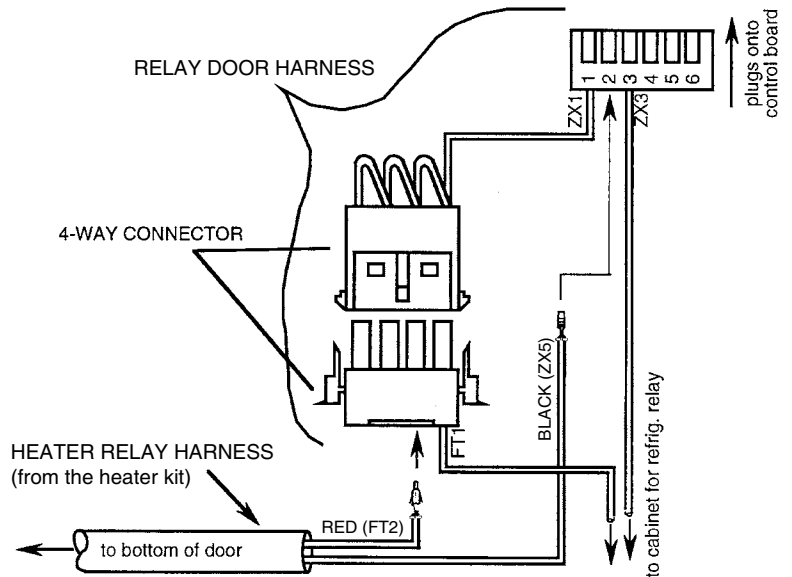

**FIGURE D**

**ANY QUESTIONS? CONTACT ROYAL VENDORS' CUSTOMER SERVICE DEPARTMENT IN NORTH AMERICA, CALL TOLL FREE 1 800 931 9214**



# SERVICE BULLETIN 109

Page: 3 of 3

Date: 31 Jan 11

Revision: 10

426 Industrial Boulevard • Kearneysville WV 25430-2776 • USA  
Telephone: +1 304 728 7056 • technicalinquiry@royalvendors.com  
Toll-free in North America: 1 800 931 9214 • Fax: +1 304 725 4016  
Canada: +1 905 738 5777 • Mexico: +52 55 5203 6887  
Europe: +49 2158 95 1000 • Australia: +61 2 9890 5433

**SUBJECT:** Installation of Heater Kit

**MODELS:** Merlin III, GII VII, GIII, Merlin IV, TDV, HVV

**FIGURE E. 200722 and after only.**

## BEFORE

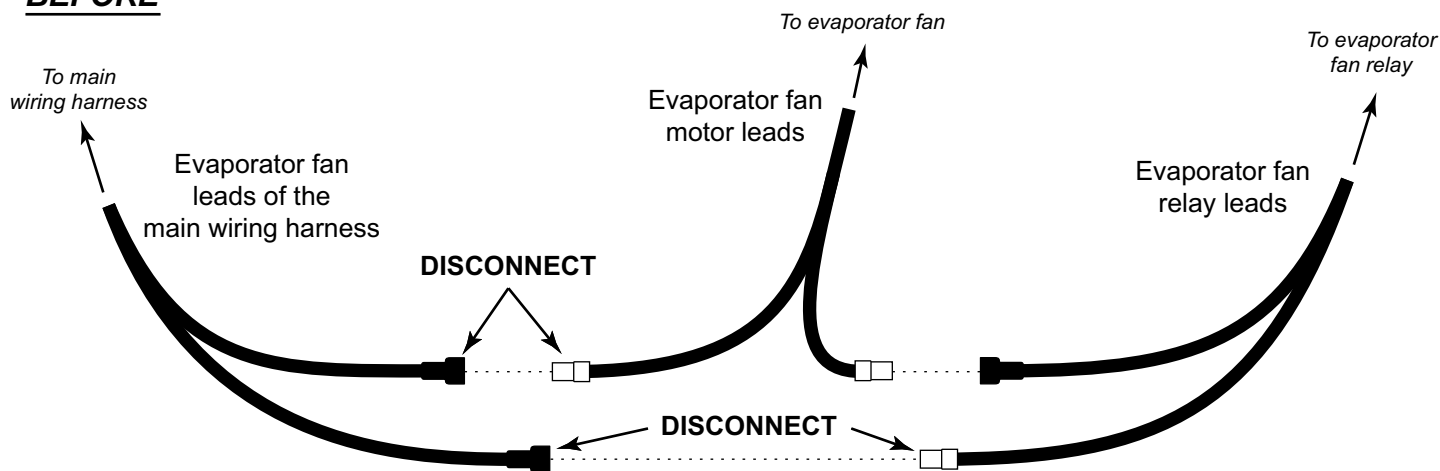

## AFTER

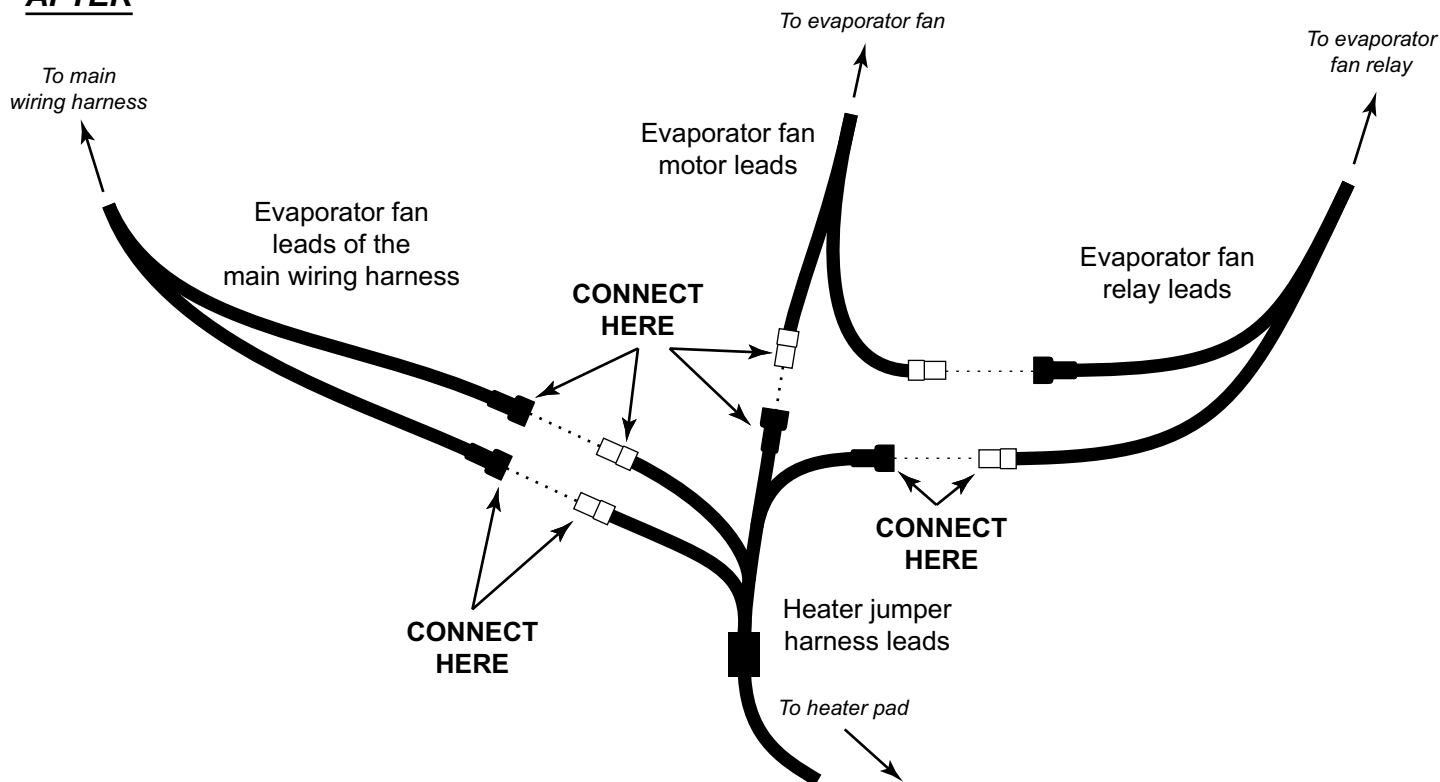

**ANY QUESTIONS? CONTACT ROYAL VENDORS' CUSTOMER SERVICE DEPARTMENT  
IN NORTH AMERICA, CALL TOLL FREE 1 800 931 9214**